

MOTOMAN AR3120

General Purpose with the AR-series

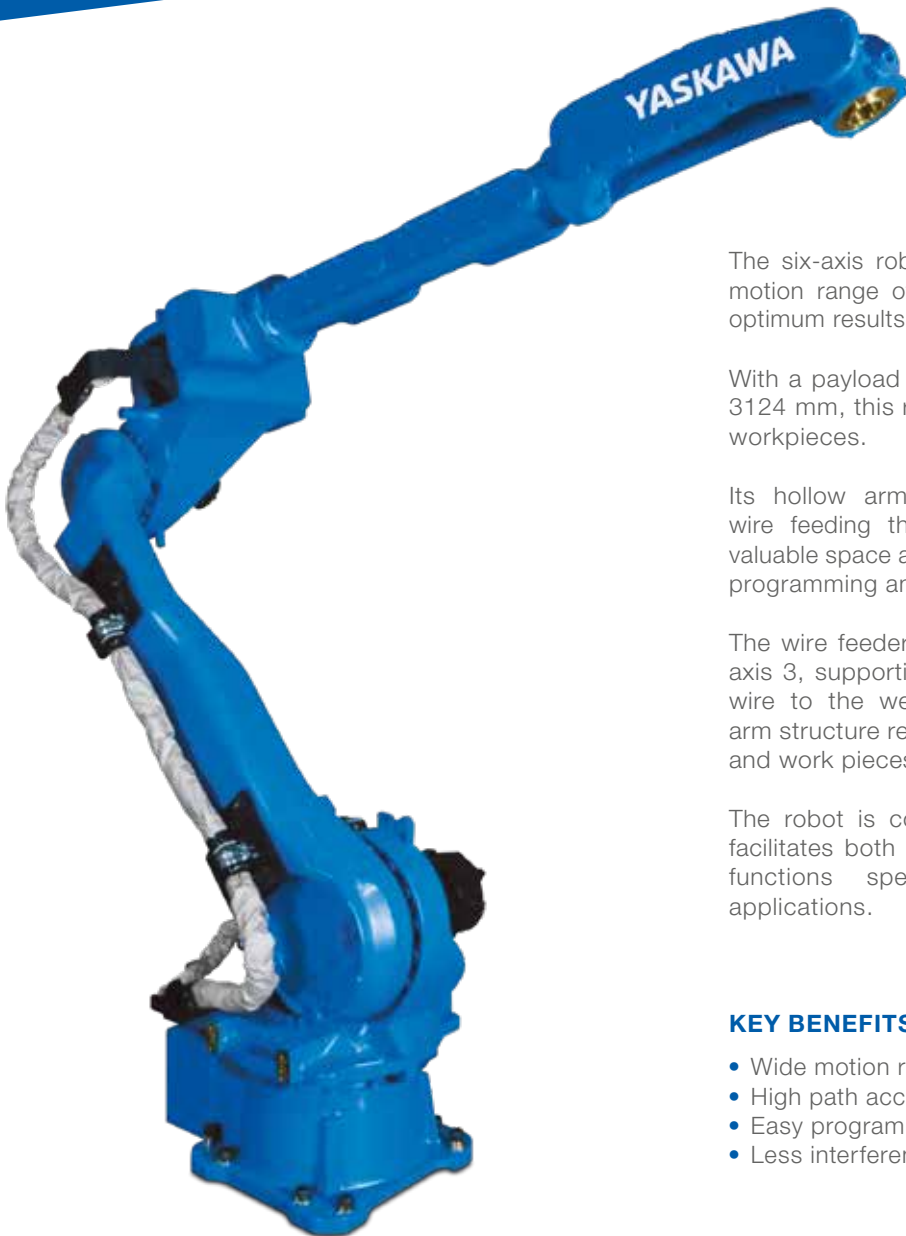

The six-axis robot MOTOMAN AR3120 provides the widest motion range of our AR-series and high path accuracy for optimum results of general purpose applications.

With a payload of up to 20 kg and a motion range of 3124 mm, this robot supports applications in bulky workpieces.

Its hollow arm design enables leading the cables and wire feeding through the arm to the wrist, which saves valuable space around it. The MOTOMAN AR3120 allows easy programming and enables high freedom of motion.

The wire feeder can be mounted in the prepared space at axis 3, supporting short distance and centric supply of the wire to the weld torch. The streamlined, slightly bowed arm structure reduces the interference area between the jigs and work pieces.

The robot is controlled by the YRC1000 controller which facilitates both programming and use with a wide range of functions specially designed for general purpose applications.

KEY BENEFITS

- Wide motion range
- High path accuracy
- Easy programming
- Less interferences due to optimized design

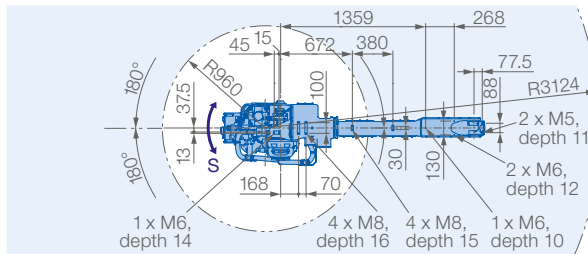
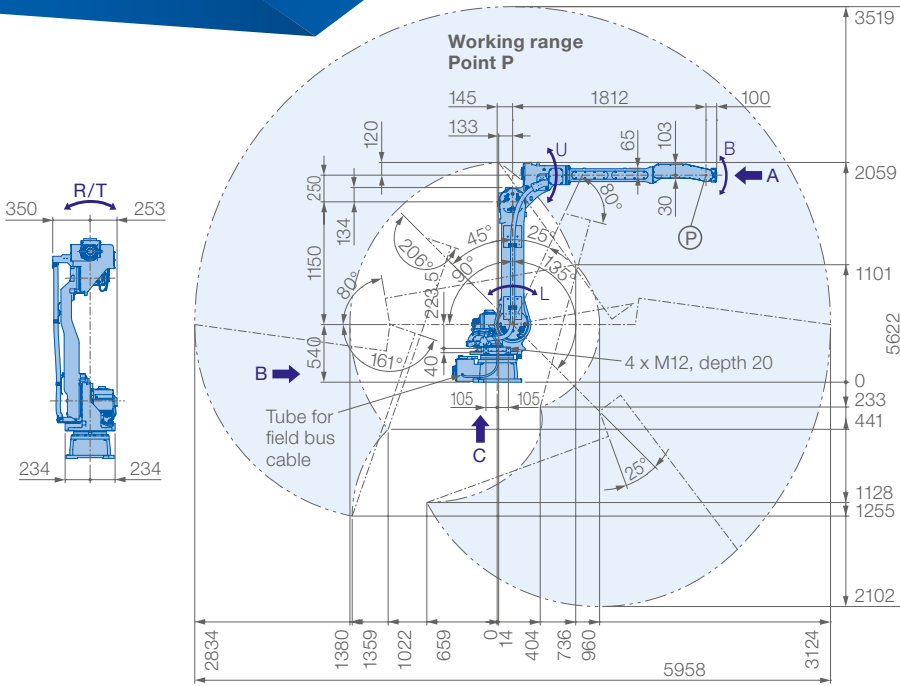

Prevent interaction of the robot with:

- Corrosive gases, liquids or explosive gases
- Exposure to water, oil or dust
- Excessive electrical noise (plasma)

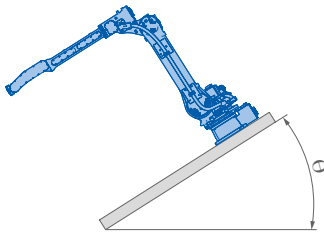

Allowable wrist load

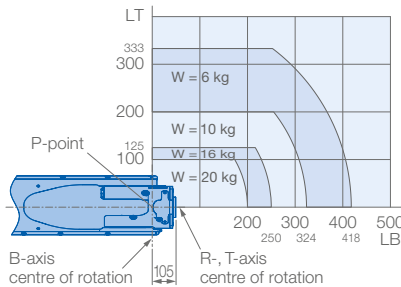

ViewA

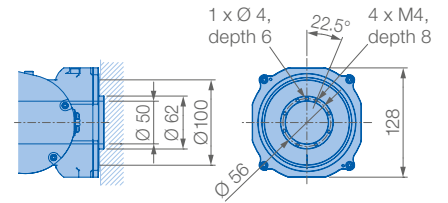

ViewB

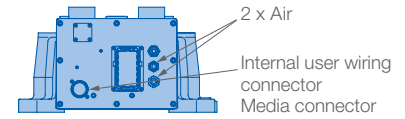

ViewC

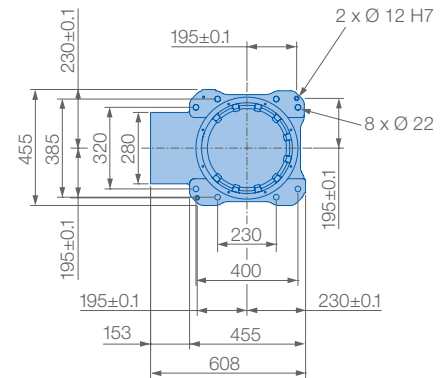

Mounting options: Floor, ceiling, wall, tilt*

Protection class: Main axes (S, L, U) IP54, wrist IP67

* tilt with condition of angle – see table below

Robot installation angle θ [deg.]	S-axis operating range [deg.]
$0 \leq \theta \leq 30$	± 180 degrees or less (no limit)
$30 < \theta \leq 35$	± 60 degrees or less
$30 < \theta \leq 45$	± 45 degrees or less
$45 < \theta$	± 30 degrees or less

Specifications AR3120

Axes	Maximum motion range [°]	Maximum speed [°/sec.]	Allowable moment [Nm]	Allowable moment of inertia [kg · m ²]	Controlled axes	6
S	± 180	180	–	–	Max. payload [kg]	20
L	+135/–90	180	–	–	Repeatability [mm]	± 0.07
U	+206/–80	180	–	–	Max. working range R [mm]	3124
R	± 200	400	39.2	1.05	Temperature [°C]	0 to +45
B	± 150	430	39.2	1.05	Humidity [%]	20 – 80
T	± 455	630	19.6	0.75	Weight [kg]	560
					Power supply, average [KVA]	2.0

Yaskawa Europe GmbH

Robotics Division
Yaskawastraße 1
85391 Allershausen
Germany

Tel. +49 (0) 8166 90-0
robotics@yaskawa.eu.com
www.yaskawa.eu.com

YR-1-06VXHL20-A00
B-09-2020, A-No. 207082