

YASKAWA

Perfect for the semiconductors
of tomorrow

DD Motor Driven Wafer Handling Robot

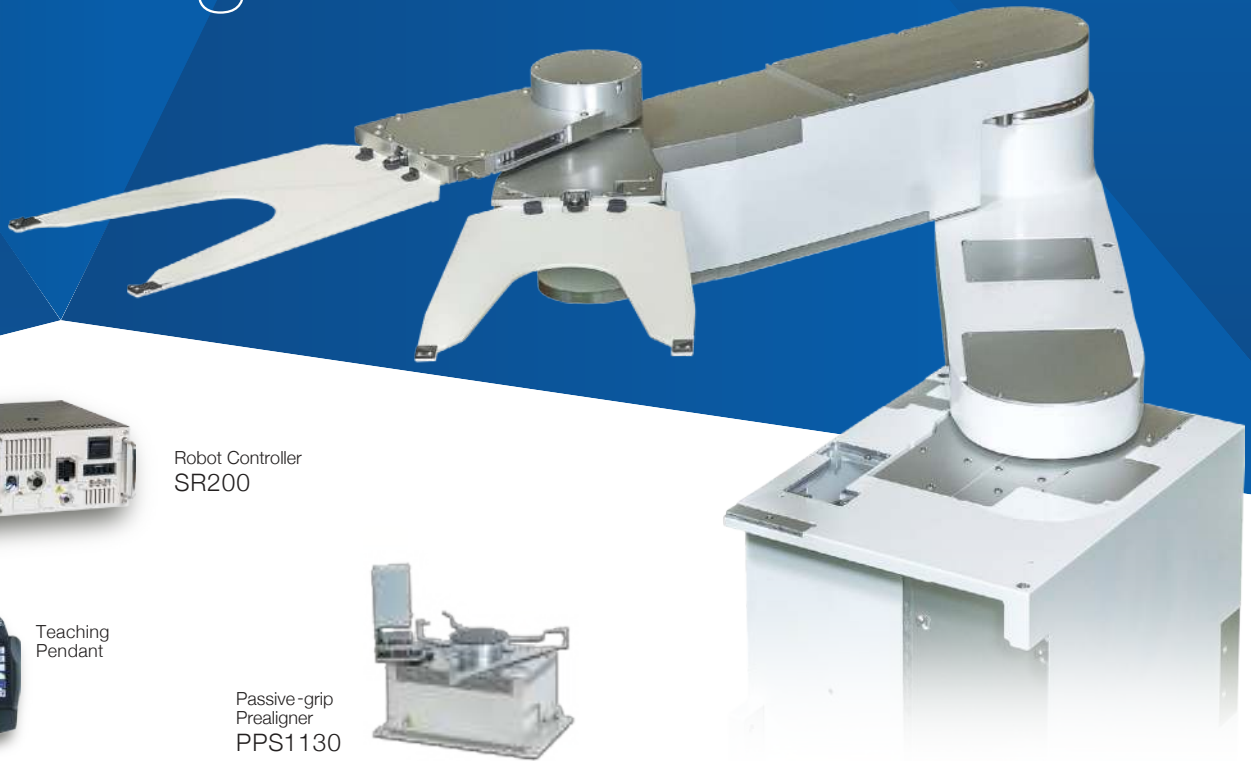

Robot Controller
SR200



Teaching
Pendant



Passive-grip
Prealigner
PPS1130

Semiconductor Wafer Handling Robot

SEMISTAR - GEKKO MD124 D

Introducing a robot optimized for the near future of
miniaturization and multi-layering.

The GEKKO MD124D powered by direct drive motors achieves
precise and quick transfer with minimum stress to wafers.

Vibration **0.25** G or less*1

Repeatability \pm **0.02** mm

Absolute positioning accuracy **0.05** mm

Direct
drive
motor

Low
vibration
High
accuracy

Low
wafer
stress

*1: This value represents the vertical direction of the end effector when the arm extends or retracts.

Note: The above values are just some examples of results obtained using Yaskawa's in-house measurement conditions and are not official product specifications.

SEMISTAR -GEKKO MD124D

■ Manipulator & Preamplifier Specifications

Items	Specifications
Applicable Wafer Size	300 mm (SEMI compliant)
Wafer Grip Method	Passive grip (vacuum and edge grip are also available)
Length of Standard EE*1	345 mm for 300-mm wafer
Number of Axes	5 axes
Arm Type	Single
EX-axis (Extension)*2	1215 mm
TH-axis (Rotation)	330°
Z-axis (Elevation)	480 mm
H-axis (EE Rotation)	440°
Minimum Rotation Radius*1	510 mm
Repeatability*1	0.05 mm (P-P)
Approx. Mass	86 kg
Clean Class*3	ISO class 1
MCBF (SEMI F10 Compliant)	15 M cycles or more
Operating Environment	Temperature: +20°C to +30°C Humidity: 35% to 55%RH (non-condensing)
Storage Environment	Temperature: 0°C to +40°C Humidity: 20% to 80%RH (non-condensing)
Altitude	1000 m or less
Atmosphere	Free from explosive, inflammable, and corrosive gas
Applicable Wafer Size	300 mm
Wafer Grip Method	Passive grip
Detection Target	Notch
Material of Wafer	Silicon*4
Alignment Accuracy	±0.1°
Alignment Time	5.0 s or less
Approx. Mass	8.5 kg

■ Controller Specifications

Items	Specifications
Dimensions	425 (W) × 300 (D) × 133 (H) mm (Protrusions are not included)
Approx. Mass	13 kg max.
Power Supply	Three-phase 200 VAC to 240 VAC (+10% to -15%), 50/60 Hz Single-phase 200 VAC to 240 VAC (+10% to -15%), 50/60 Hz
Communications (Connection to Host)	Ethernet (10BASE-T/100BASE-TX) 2 ports
Optional Board Slot	2 slots
Number of Control Axes	8 axes max.
Applicable Standards	SEMI S2, S8, F47 UL61010-1 ISO 13849-1, Category 3 (PL=d), etc.

- *1: 300-mm wafer (SEMI compliant), using Yaskawa's standard 300-mm EE
- *2: Center of manipulator rotation to center of wafer when using Yaskawa's standard 300-mm EE
- *3: Based on Yaskawa's recommended installation conditions when used in a downflow environment of 0.3 m/s
- *4: SEMI compliant silicon wafer. Contact your Yaskawa representative for quartz wafer use. Related parameters need to be adjusted and evaluated. (Yaskawa has experiences with quartz wafer.)

■ Dimensions Units: mm

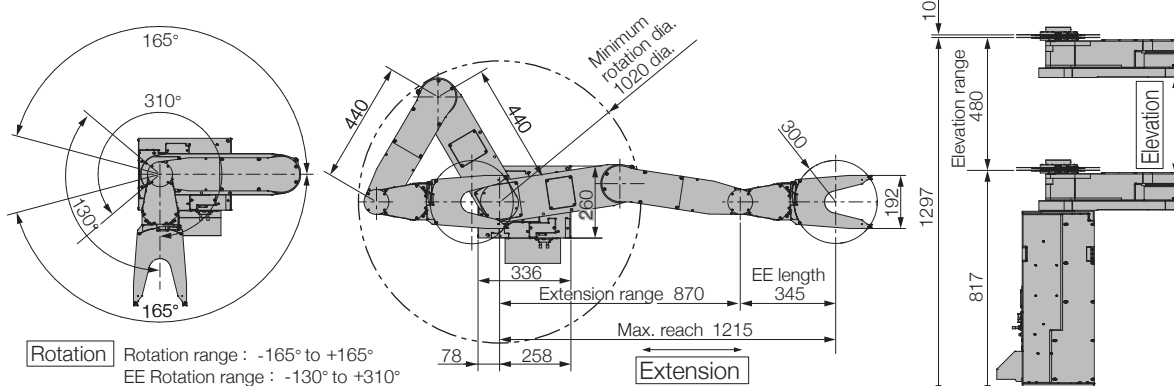
**YASKAWA ELECTRIC CORPORATION**

2-1 Kurosakishiroishi, Yahatanishi-ku, Kitakyushu, 806-0004, Japan
Phone: +81-93-645-7703 Fax: +81-93-645-7802

YASKAWA AMERICA, INC. (MOTOMAN ROBOTICS DIVISION)

100 Automation Way, Miamisburg, OH 45342, U.S.A.
Phone: +1-937-847-6200 Fax: +1-937-847-6277

YASKAWA EUROPE GmbH (ROBOTICS DIVISION)

Yaskawastrasse 1, 85391, Allershausen, Germany
Phone: +49-8166-90-100 Fax: +49-8166-90-103

YASKAWA NORDIC AB

Verkstadsgatan 2, Box 504, SE-385 25 Torsås, Sweden
Phone: +46-480-417-800 Fax: +46-486-414-10

YASKAWA ELECTRIC (CHINA) CO., LTD.

22F, One Corporate Avenue, No.222 Hubin Road, Huangpu District, Shanghai 200021, China
Phone: +86-21-5385-2200 Fax: +86-21-5385-3299

YASKAWA SHOUGANG ROBOT CO., LTD.

No.7 Yongchang North Road, Beijing E&T Development Area, Beijing 100076, China
Phone: +86-10-6788-2858 Fax: +86-10-6788-2878

YASKAWA ELECTRIC KOREA CORPORATION

35F, Three IFC, 10 Gukjogeumyung-ro, Yeongdeungpo-gu, Seoul, 07326, Korea
Phone: +82-2-784-7844 Fax: +82-2-784-8495

YASKAWA ELECTRIC TAIWAN CORPORATION

12F, No.207, Sec. 3, Beishin Rd., Shindian District, New Taipei City 23143, Taiwan
Phone: +886-2-8913-1333 Fax: +886-2-8913-1513

YASKAWA ASIA PACIFIC PTE. LTD.

30A Kallang Place, #06-01, 339213, Singapore
Phone: +65-6282-3003 Fax: +65-6289-3003

YASKAWA ELECTRIC (THAILAND) CO., LTD.

59, 1st-5th Floor, Flourish Building, Soi Ratchadapisek 18, Ratchadapisek Road, Huaykwang, Bangkok 10310, Thailand
Phone: +66-2-017-0099 Fax: +66-2-017-0199

PT. YASKAWA ELECTRIC INDONESIA

Secure Building-Gedung B Lantai Dasar & Lantai 1 Jl. Raya Protokol Halim Perdanakusuma, Jakarta 13610, Indonesia
Phone: +62-21-2982-6470 Fax: +62-21-2982-6471

YASKAWA INDIA PRIVATE LIMITED (ROBOTICS DIVISION)

#426, Udyog Vihar Phase-IV, Gurgaon, Haryana 122016, India
Phone: +91-124-475-8500 Fax: +91-124-475-8542

In the event that the end user of this product is to be the military and said product is to be employed in any weapons systems or the manufacture thereof, the export will fall under the relevant regulations as stipulated in the Foreign Exchange and Foreign Trade Regulations. Therefore, be sure to follow all procedures and submit all relevant documentation according to any and all rules, regulations and laws that may apply. Specifications are subject to change without notice for ongoing product modifications and improvements.

Yaskawa Europe Technology Ltd.

13 Hamelacha st. Afek Industrial Zone, Rosh Ha'ayin 4809129 Israel
Tel: +972-73-2400800 Fax: +972-73-2400888
www.yaskawa.co.il info@yaskawa.co.il

YASKAWA