

YASKAWA

MOTOMAN SG650

Picking, Packing & Handling
with the SG-series

The robust MOTOMAN SG650 scara-robot features a wide motion range due to its compact design.

It is particularly suitable for application when high speed and accuracy is required, for example picking and packing, dispensing and feeding. Small interference contours allow the robots working together in confined spaces. Internal cabling enables a reliable workflow and saves extensive maintenance.

The SG650 is driven by the compact and lightweight YRC1000micro controller.

KEY BENEFITS

- Fast, powerful and reliable
- Wide motion range
- Compact and robust design
- Internal cabling
- High repeatability and accuracy
- Ideal for applications in confined spaces
- Easy integration and high dynamics
- Easy maintenance



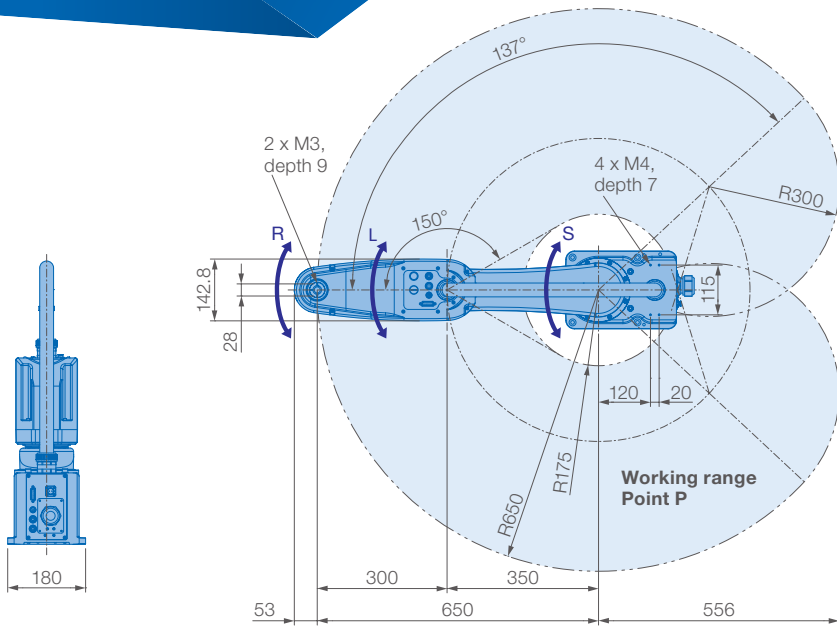

View A

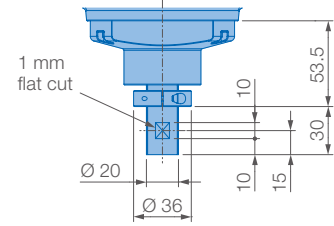

View B

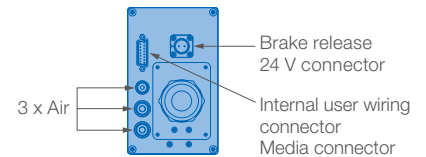

View C

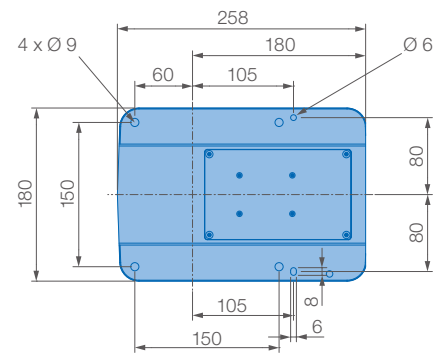

Mounting option: Floor

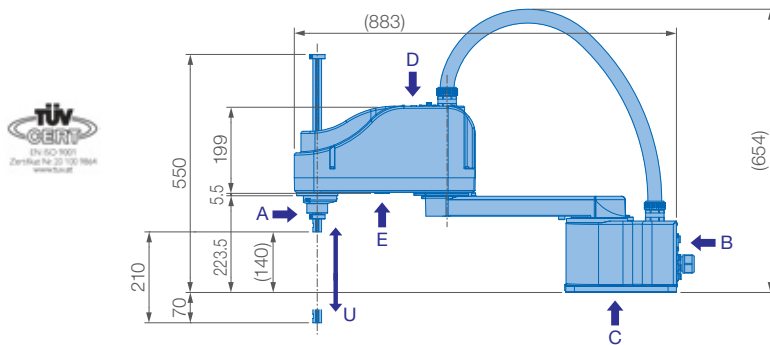

Maximum payload of the wrist axis and the R-axis allowable inertia

Please make sure that the load (total amount of hand and workpiece) does not exceed the values in the table.

Max. Payload [kg]	6
R-axis allowable inertia [kg · m ²]	0.12
Max. allowable eccentric distance of the mass center point [mm]	150

View D

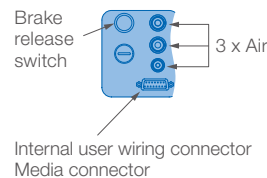

View E

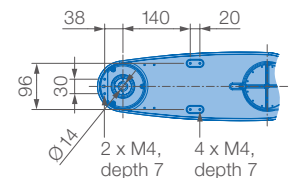

Specifications SG650						
Axes	Maximum motion range [°]	Maximum speed [°/sec.]	Allowable moment [Nm]	Allowable moment of inertia [kg · m ²]	Controlled axes	4
S	±137	450	-	-	Max. payload [kg]	6
L	±150	730	-	-	Repeatability [mm]	±0.01
U	+210	1300 mm/sec.	-	-	Max. working range R [mm]	650
R	±360	2500	-	0.12	Temperature [°C]	0 to +40
					Humidity [%]	20 – 80
					Weight [kg]	19
					Power supply, average [KVA]	1

Yaskawa Europe GmbH

Robotics Division
Yaskawastraße 1
85391 Allershausen
Germany

Tel. +49 (0) 8166 90-0
robotics@yaskawa.eu.com
www.yaskawa.eu.com

YR-1-04SX650-A00
A-03-2020, A-No. 210493

All drawing dimensions in mm. Technical data may be subject to change without previous notice. Please request detailed drawings at robotics@yaskawa.eu.com.