

MOTOMAN MPP3H

Handling, Picking & Packing
with the MPP-series



The MOTOMAN MPP3H 4-axis high-speed robot with parallel kinematic system combines the speed of the delta design with a high payload capacity and a large working range. Due to the high torque of the fourth axis, the so-called wrist axis, the MOTOMAN MPP3H moves payloads of up to 3 kg at unprecedented speeds. This delta robot was developed for a wide spectrum of industries, such as food and beverage, pharmaceutical and the automotive sector.

The MPP3H is driven by Yaskawas compact FS100 controller and is available with advanced technologies such as MotoSight, MotoPick and conveyor tracking.

KEY BENEFITS

- Protection classification IP67
- Cleanroom class ISO 5 (with 50 and 100 % speed)
- Payloads with unprecedented speed:
 - 150 cycles per minute with 3 kg payload
 - 185 cycles per minute with 1 kg payload
- Total stroke of 500 mm with a working range of 1300 mm
- High-precision, high-speed conveyor tracking
- Maximum machine accuracy
- Compact installation space: 684 mm diameter

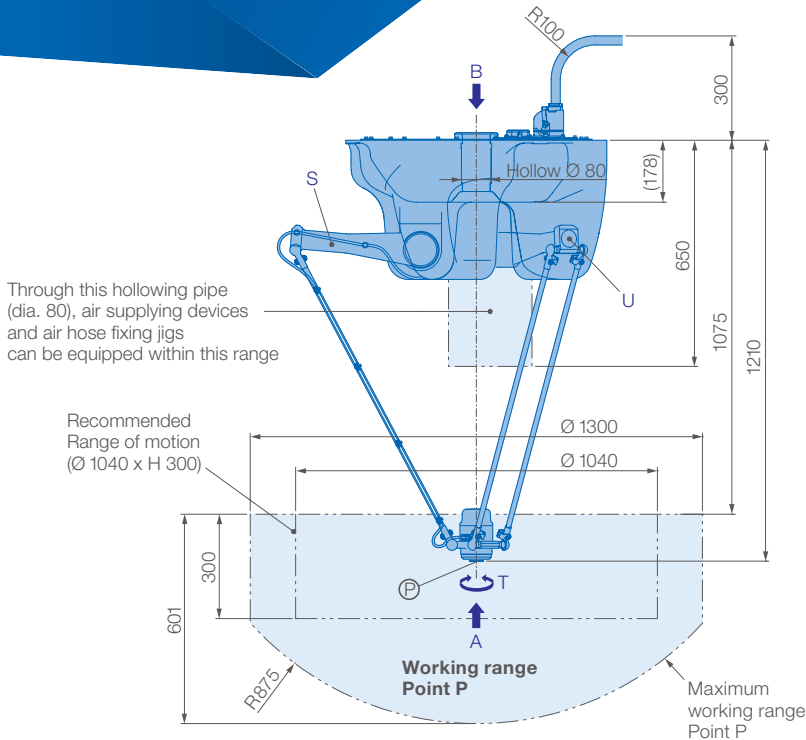

View A

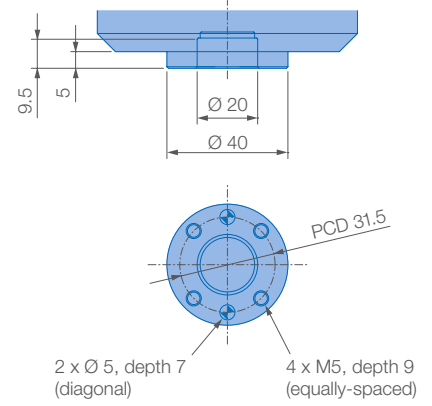

Mounting option: Ceiling
Protection class: IP67

Allowable wrist load

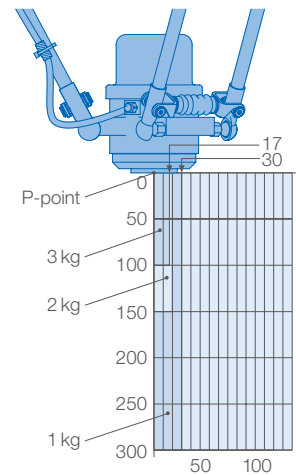

For planning Multi-Robot-Systems please refer to your Yaskawa sales contact.

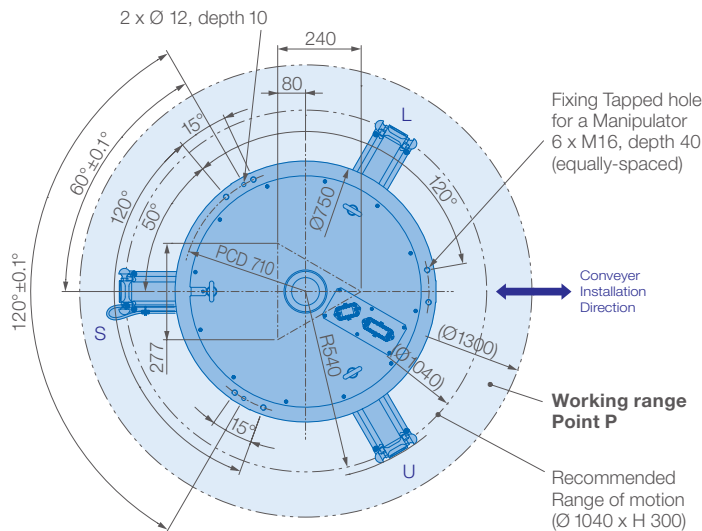

Specifications MPP3H

Plattern	Payload [kg]	CPM *	Payload [kg]	CPM *	Controlled axes	
					Max. payload [kg]	
25-305-25	1	230	3	170	Repeat. pos. accuracy [mm]	±0.1
300-400-100	1	100	3	80	Repeat. rotational accuracy of T-axis [arc x min -1]	±1
70-700-70	1	130	3	95	Max. working range R [mm]	1300
	Conveyor speed ** [mm/s]		Conveyor position repeat accuracy ** [mm]		Temperature [°C]	0 to +40
	800		1.0		Humidity [%]	20 - 80
	1300		1.5		Weight [kg]	115
	2000		3.0		Power supply, average [KVA]	1.5
					IP class	IP67
				IPA cleanroom class	5.0	

* Cycle time without picking time and product.

** Values determined under test conditions, differences possible depending on application.

Yaskawa Europe GmbH

Robotics Division
Yaskawastraße 1
85391 Allershausen
Germany

Tel. +49 (0) 8166 90-0
robotics@yaskawa.eu.com
www.yaskawa.eu.com

YR-MPP0003H-A00
B-03-2020, A-No. 170962