

# YASKAWA

# MOTOMAN GP400

Handling & General Applications  
with the GP-series

The 6-axis MOTOMAN GP400 is a versatile, powerful robot offering superior performance for a variety of applications. It provides a high payload of 400 kg and a wide motion range, which especially enables the handling of large work pieces.

The robot features a parallel-link construction for strength, rigidity and stabilization of high moment and inertia loads. The GP400 also has heavy-duty bearings which provide a smooth arm rotation.

The MOTOMAN GP400 is available with the PLd Category 3 Functional Safety Unit (FSU).



## KEY BENEFITS

- Fast, flexible and powerful
- High payload: 400 kg
- Wide motion range: 2942 mm
- Parallel-link construction
- Heavy-duty bearings for smooth arm rotation
- Enhanced safety functions

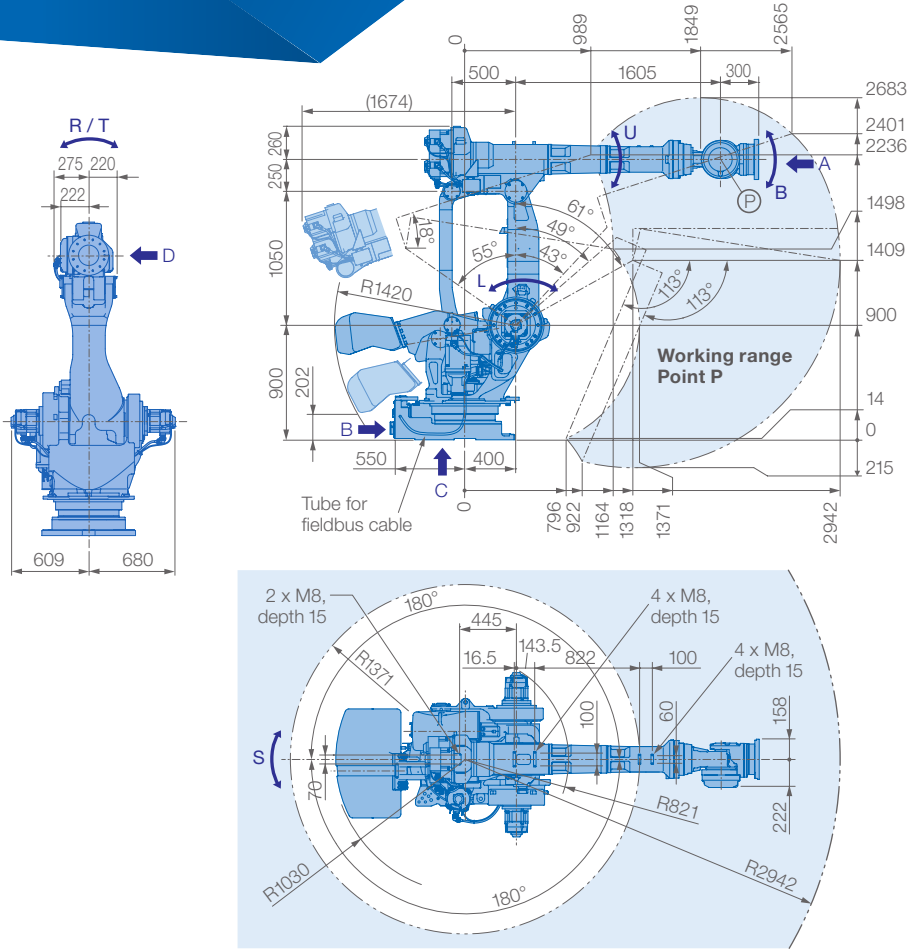

View A

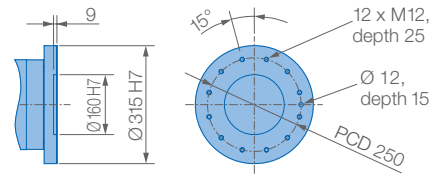

View B

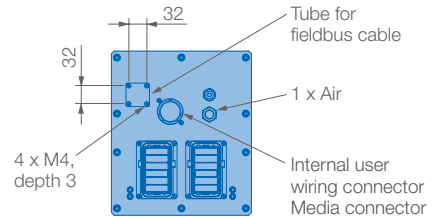

View C

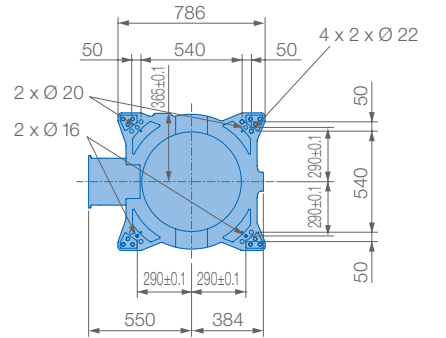

Mounting option: Floor  
Protection class: IP30/IP67

View D

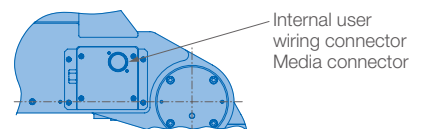

Allowable wrist load

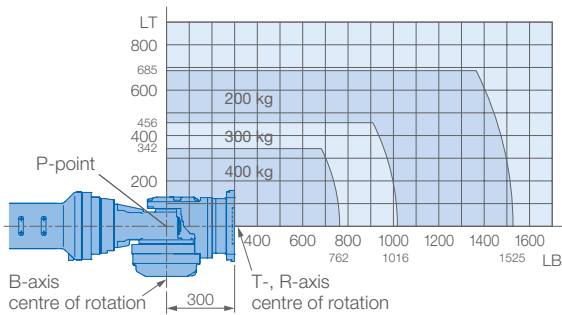

Specifications GP400					
Axes	Maximum motion range [°]	Maximum speed [°/sec.]	Allowable moment [Nm]	Allowable moment of inertia [kg · m <sup>2</sup> ]	Controlled axes
					6
					Max. payload [kg]
					400
					Repeatability [mm]
					±0.1
					Max. working range R [mm]
					2942
					Temperature [°C]
					0 to +45
					Humidity [%]
					20 – 80
					Weight [kg]
					2840
					Power supply, average [KVA]
					7.0

Yaskawa Europe GmbH

Robotics Division  
Yaskawastraße 1  
85391 Allershausen  
Germany

Tel. +49 (0) 8166 90-0  
robotics@yaskawa.eu.com  
www.yaskawa.eu.com

YR-1-06VX400-A00  
B-10-2020, A-No. 195952