

MOTOMAN GP250

Handling & General Applications
with the GP-series



The 6-axis MOTOMAN GP250 is a versatile, high speed robot offering superior performance for a variety of applications, like material handling, machine and press tending.

Despite of providing a high payload of 250 kg and the wide motion range of 2710 mm, the MOTOMAN GP250 was designed with a width of 816 mm, therefore valuable floor space can be saved.

The vibration control system uses higher axis operation speed and speed reducer rigidity to allow fast acceleration of short movements. By reducing cycle times, this system realises high increases in productivity.

KEY BENEFITS

- Fast, flexible and powerful
- High payload: 250 kg
- Wide motion range: 2710 mm
- Maximum performance using minimal floor space

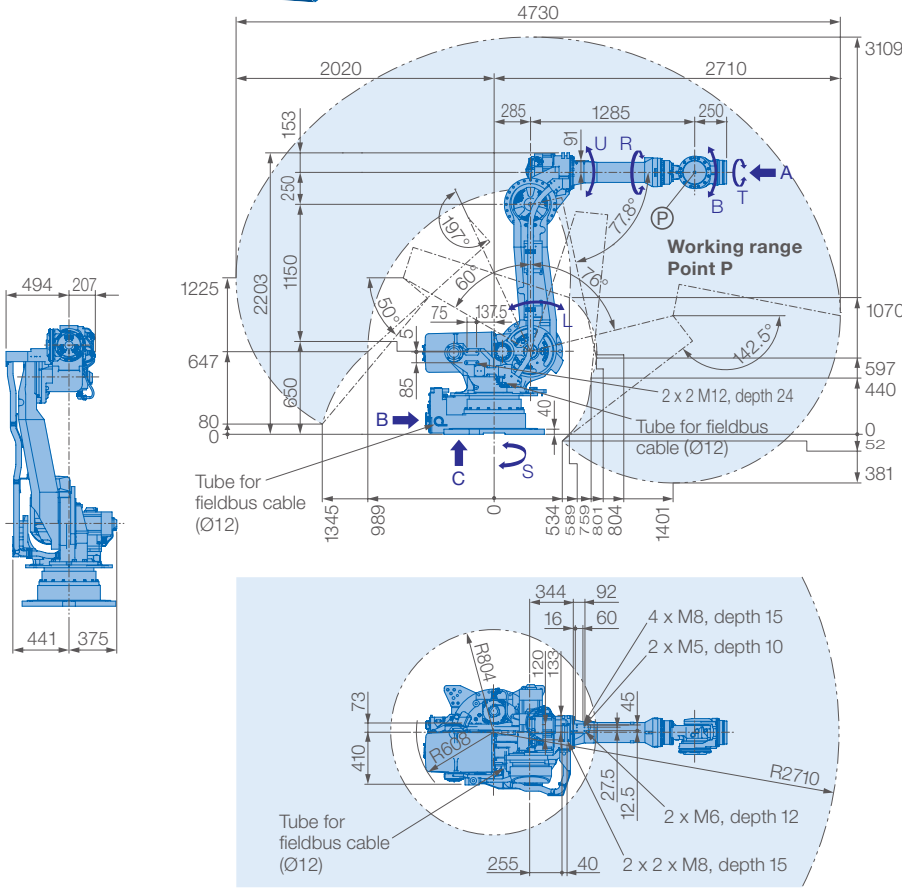

View A

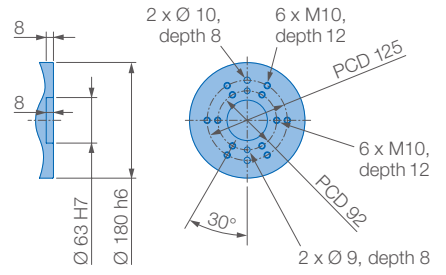

View B

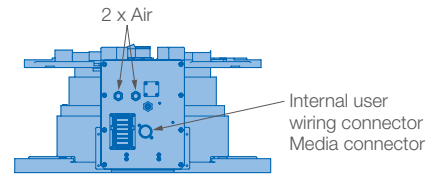

View C

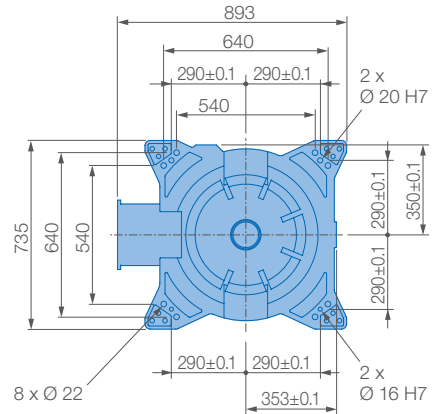

Mounting option: Floor
Protection class: IP54/IP67

Allowable wrist load

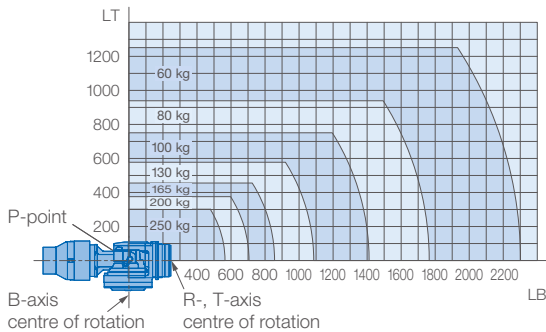

Specifications GP250						
Axes	Maximum motion range [°]	Maximum speed [°/sec.]	Allowable moment [Nm]	Allowable moment of inertia [kg · m ²]	Controlled axes	6
S	±180	100	-	-	Max. payload [kg]	250
L	+76/-60	90	-	-	Repeatability [mm]	±0.05
U	+197/-77.8	97	-	-	Max. working range R [mm]	2710
R	±360	120	1385	317	Temperature [°C]	0 to +45
B	±125	120	1385	317	Humidity [%]	20 - 80
T	±360	190	735	200	Weight [kg]	1345
					Power supply, average [KVA]	5.0

Yaskawa Europe GmbH

Robotics Division
Yaskawastraße 1
85391 Allershausen
Germany

Tel. +49 (0) 8166 90-0
robotics@yaskawa.eu.com
www.yaskawa.eu.com

YR-1-06VX250-A00
B-10-2020, A-No. 195948