

L1000A

Geared and Gearless Elevator Drive



iQRISE™

For High Performance Elevator Applications

Experience & Innovation

For more than 100 years, Yaskawa has been manufacturing and supplying drive products for machine building and industrial automation. Our standard products as well as tailor-made solutions are famous and have a high reputation for outstanding quality and durability.

Yaskawa has proven success of manufacturing and supplying drives to the elevator industry: an installed base of over 1,000,000 elevator drives installed and operational.

The L1000A Drive Series is a dedicated drive for elevator applications suitable for both modernization projects and new installations.



- 200-240 VAC (2 to 150 HP)
- 380-480 VAC (2 to 500 HP)
- 500-600 VAC (2 to 250 HP)

The L1000A provides high-performance characteristics offering a set of attractive features:

- Single drive for either IM or PM motor control
- Peak current ratings of 200% or more based on NEC amps
- Auto-tuning routines optimally match L1000A to IM/PM motors (coupled or uncoupled)
- Yaskawa Quality – designed for more than 70,000 hours of maintenance-free operation
- Designed for extreme quiet motor operation
- Enhanced features for highest passenger comfort (i.e., torque ripple suppression)
- Additional functions to reduce floor-to-floor times
- Powerful keypad and I/O interface to simplify elevator controller integration
- Easy serviceability and maintainability with lifetime monitors and removable terminals with parameter backup
- Elevator terminology for ease of operation
- Rescue operation control flexibility
- Reduce system cost with TÜV-compliant functional safety (STO)
- Advanced high speed elevator control

Advanced Motor/Drive Technology

High-performance current vector control technology for induction and PM motor operation.

- Single parameter to switch between the various motor types
- Perfect for a wide range of elevator applications

Control Modes

- PM motors (SPM/IPM): Closed Loop Vector for PM
- Induction motors (IM): V/f control, Open-Loop Vector, Closed-Loop Vector Control

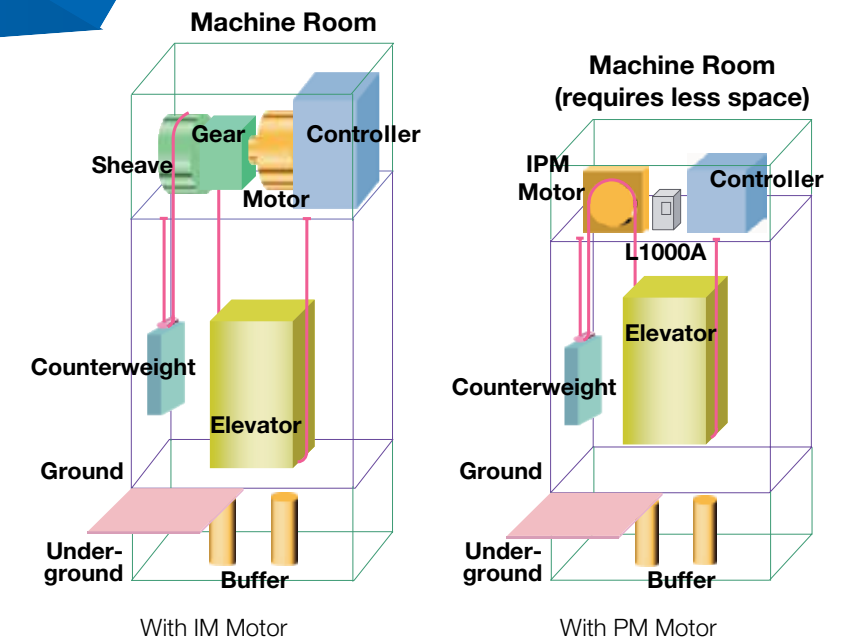

Powerful Torque Characteristics

Control Mode	Starting Torque	Speed Range	Motor Encoders and Option Cards
Closed-loop vector control for IM motors: For geared and gearless induction motors	200% at 0 rpm	1:1500	Incremental encoders: - Line driver - Complementary
Closed-loop vector control for PM motors: For geared and gearless permanent magnet motors	200% at 0 rpm	1:1500	Incremental encoders: - Line driver - Complementary Absolute encoders: - EnDat 2.1/01, 2.2/01, 2.2/22 - HEIDENHAIN ERN1387/487 - Hiperface SRS 50/60
Open-loop vector control for IM motors: For modernization and new installations	200% at 1 Hz	1:120	Not required
V/f control for IM motors: For modernization applications, when auto-tuning is not possible (e.g., motor current is not known)	150% at 3 Hz	1:40	Not required

Simple Setup

Auto-Tuning Options

Auto-Tuning methods optimize motor handling performance. Rotational Auto-Tuning and Stationary Auto-Tuning are available for both induction motors and PM motors.

Auto-Tuning for Induction Motors	
Rotational Auto-Tuning	Rotational Auto-Tuning gives the most accurate results and is highly recommended (ropes have to be removed).
Stationary Auto-Tuning 1	Automatically calculates motor parameters needed for vector control (choose this tuning if ropes cannot be removed).
Stationary Auto-Tuning for Line-to-Line Resistance	Used for V/f control or vector control modes when the drive was previously set up properly and the motor cable has changed.
Stationary Auto-Tuning 2	Used when the motor test report is available. The no-load current and the rated slip must be entered from the test report. All other motor-related parameters are calculated automatically (use if ropes cannot be removed).

Auto-Tuning for PM Motors	
Motor Parameter Settings	Use when the motor test report is available. Input the motor data from the test report.
Stationary Auto-Tuning	Use when the motor test report is not available. Input motor data from the nameplate. The drive automatically calculates the other motor-related parameters.
Stationary Auto-Tuning for Stator Resistance	Automatically calculates stator resistance only. Should be performed if the motor cable has changed.
Pole Position Auto-Tuning	Used to determine which encoder offset tuning method should be used. Checks the PM motor to determine if the stationary encoder offset auto-tuning is possible. After the initial motor auto-tuning, the Pole Position Auto-Tuning attempts to detect the rotor position without motor rotation and auto-tunes the other motor-related parameters.
Rotating Encoder Offset Auto-Tuning	Auto-tunes the encoder offset of an absolute encoder while rotating the motor. Should be performed with no load (ropes have to be removed or car must be balanced).
Stationary Encoder Offset Auto-Tuning	Auto-tunes the encoder offset of an absolute encoder without rotating the motor. Can only be used with an IPM motor. If offset cannot be tuned properly by this method, perform the Rotating Encoder Offset Auto-Tuning.

Extended Built-in Braking Transistor Range

L1000A provides built-in braking transistor for all drive models up to 40 HP

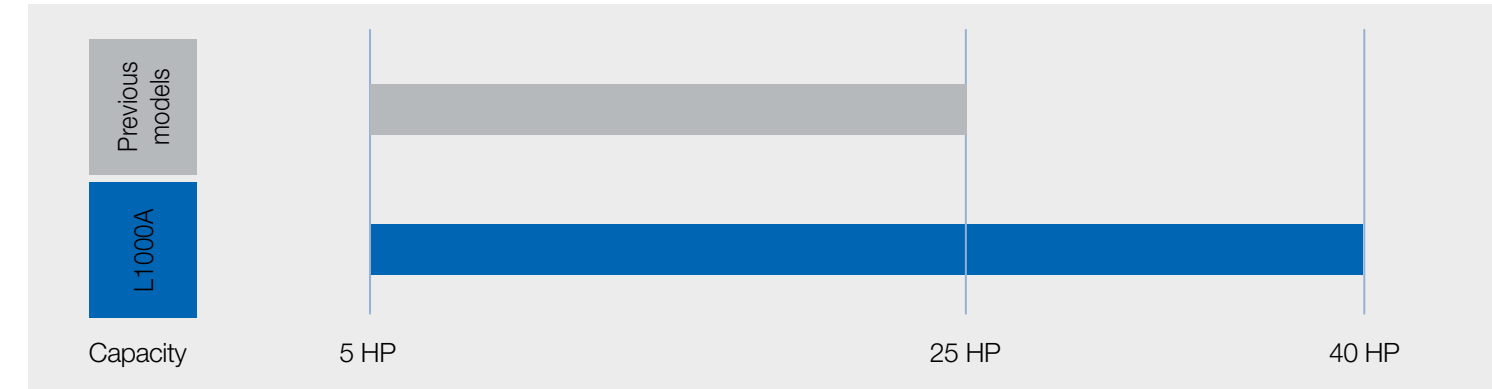

LCD Operator for Simple Parameter Handling

All standard versions are equipped with an LCD operator including:

- Elevator language and units for speed, accel/decel, and jerk rates
- Copy function: to upload and download parameter settings instantly
- Setup Mode: prepares the initial parameters to start the drive running immediately
- Verify function: checks parameters that have been changed from default values
- 13 different languages: English, Japanese, German, French, Italian, Spanish, Portuguese, Chinese, Russian, Czech, Turkish, Polish, Greek

Support Tool: DriveWizard iQrise

- The drive is equipped with a USB port for connection to a PC with DriveWizard iQrise installed
- Adjust and edit parameters, access all monitors, create customized operation sequences, and observe drive performance with the oscilloscope function
- Parameter storage
- Parameter upload/download function

* DriveWizard iQrise can be downloaded at yaskawa.com



Elevator Features

Independent Jerk Rates

- Smooth ride performance during transitions from acceleration to nominal speed and deceleration to leveling speed
- The jerk rates are used to smooth out any speed changes due to sudden changes in the motor speed
- Selectable units: seconds, ft/s³ or m/s³

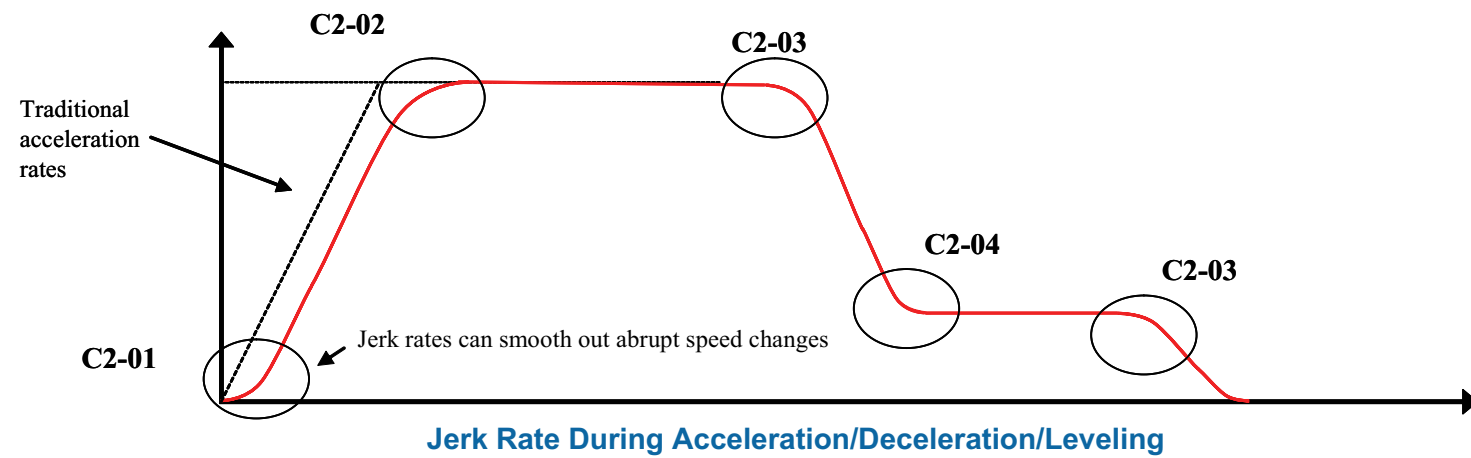

Improved Torque Ripple Suppression

- Smooth start/stop due to optimized torque ripple suppression
- Precise torque motor performance for comfortable acceleration and deceleration characteristics

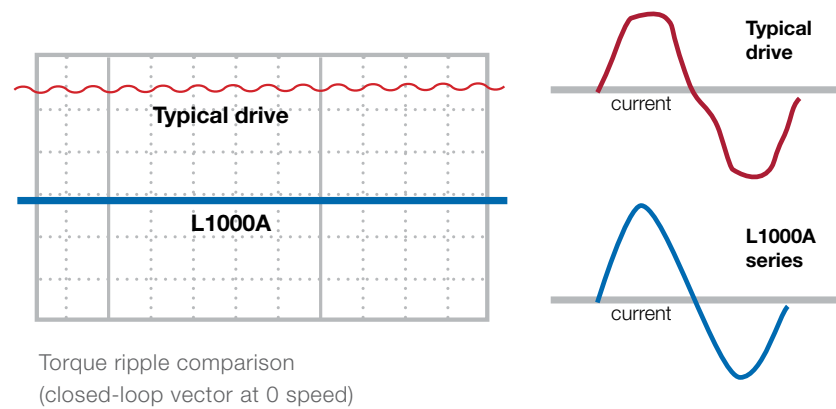

Torque Compensation at Start (Anti-Rollback) without Load Sensor

- Sensorless torque compensation function includes the Yaskawa advanced anti-rollback function, preventing shock at start to ensure a smooth start
- Anti-rollback function: provides the right amount of torque compensation to suppress shock and prevent speed variations when the brake is released.

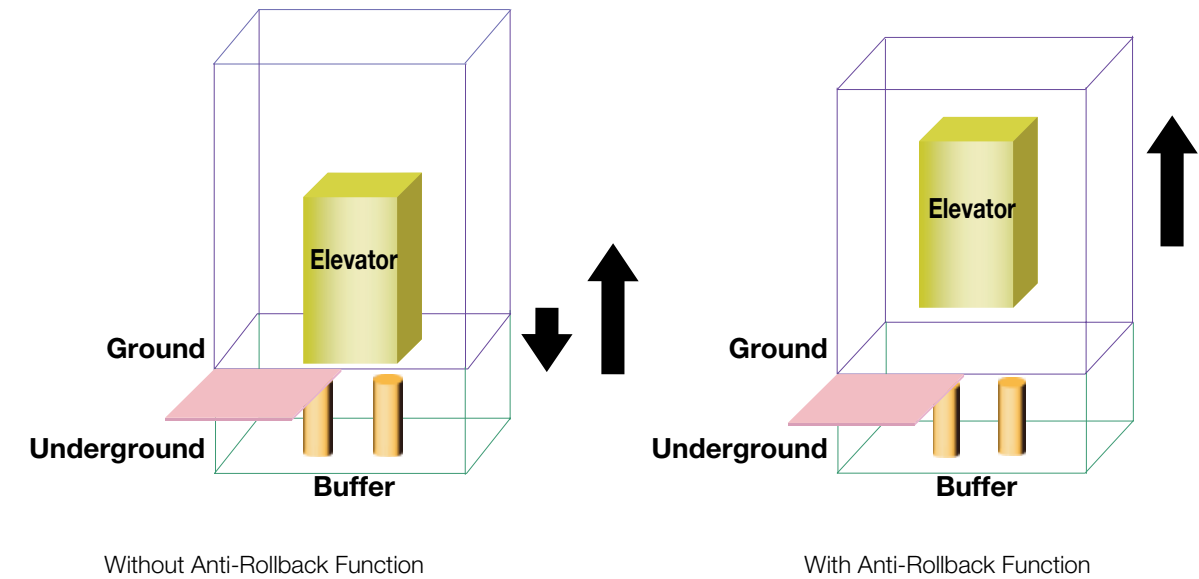

System Inertia Compensation

- Inertia compensation provides ideal speed response.
- Acceleration and deceleration compensation prevents vibration and overshoot.
- Adjustment of jerk settings for acceleration and deceleration to ensure a perfectly smooth ride.

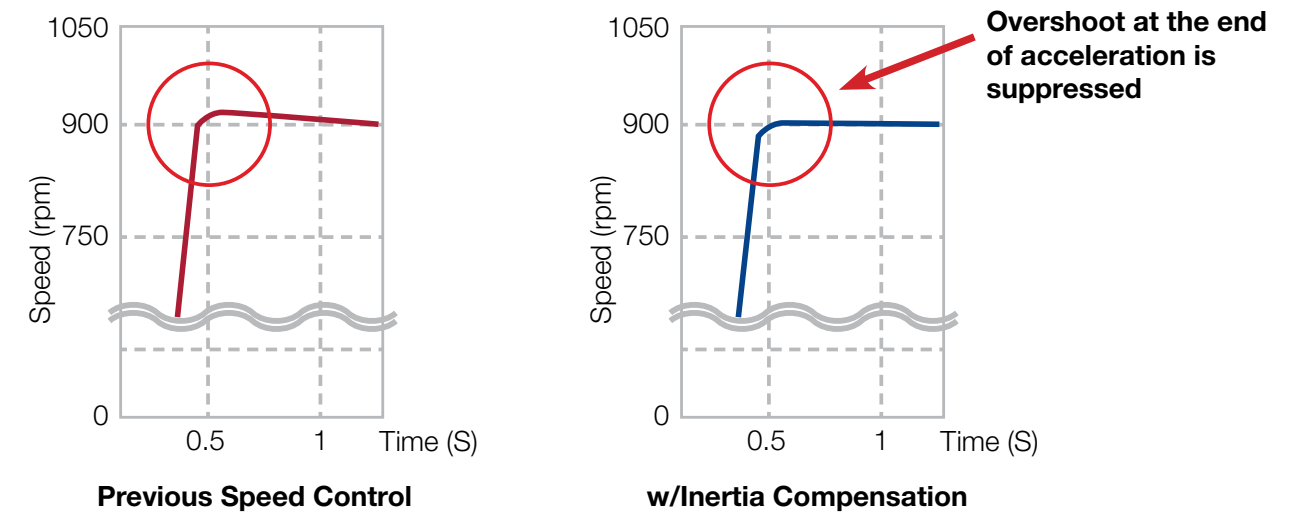

Elevator Features

UPS and Light-Load Direction Search Function for Rescue Operation

- In case of power failure, the L1000A can bring the elevator car to the next floor for evacuation using the UPS.
- A single-phase 230 V UPS or 48 to 96 VDC battery (24 V control power supply) provides the drive with the necessary power for evacuation.
- A "light-load direction search" function triggered by the controller detects the light direction of the elevator.

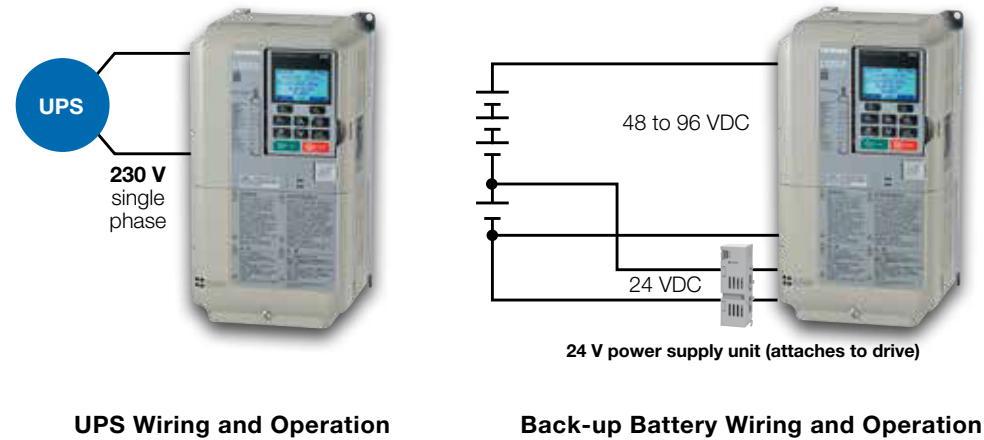

For clarity, the illustrations have been simplified, omitting several switches and control signals.

Safety Features as Standard

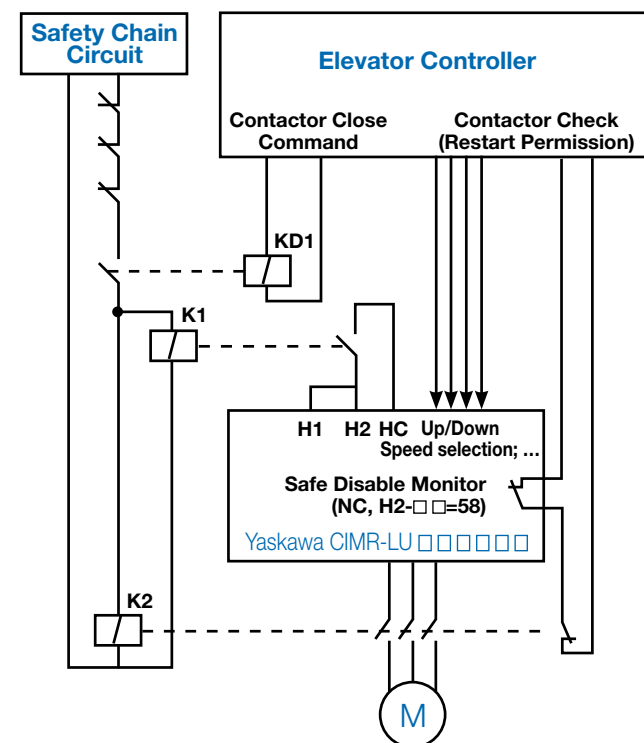

- One contactor solution according to EN81-1
- L1000A is TÜV-compliant according to EN954-1 Cat. 3, Stop Category 0, ISO13849-1 (Cat.3 Pld) and IEC/EN 61508 SIL2
- An External Device Monitor (EDM) function is available to monitor the safety status of the L1000A.
- Monitor status of input power supply: Immediately detects phase loss from the input power supply. Detection remains active when the L1000A is either running or stopped.

Removable Terminal Board with Parameter Backup Function

In the event of a failure requiring a drive replacement, the removable terminal board offers benefits to reduce downtime:

- Removable terminal board allows quick drive replacement without removing the control wiring
- Saves parameter data for fast re-initialization of previous parameter settings



Parameters Changed from Default		
Name	Number	Setting
Digital Operator Display Unit Selection	o1-03	6
Control Method Selection	A1-02	0
Speed Reference Selection	b1-01	1
Up/Down Command Selection	b1-02	1

Long Performance Life

Ten Years of Durable Performance

- Cooling fan, capacitors, relays, and IGBTs have been carefully selected and designed for a life expectancy of up to 10 years*.

* Assumes the drive is running continuously for 24 hours a day at 80% load with an ambient temperature of 40°C.

Performance Life Monitors

- Yaskawa's L1000A drive series is equipped with performance life monitors that notify the user of part wear and maintenance periods to prevent problems before they occur.

Operator Display	Corresponding Component
LT-1	Cooling fan
LT-2	Capacitors
LT-3	Inrush prevention relay
LT-4	IGBTs

- Drive outputs a signal to the control device indicating components may need to be replaced

Certifications



Product Lineup

HP	Three-Phase 200 to 240 V Class		Three-Phase 380 to 480 V Class		Three-Phase 500 to 600 V Class	
	Model CIMR-	Rated Output	Model CIMR-	Rated Output	Model CIMR-	Rated Output
2	LU2A0008	8 A	LU4A0005	5 A		
3	LU2A0011	11 A	LU4A0006	6 A	LU5A0003	3 A
4	LU2A0014	14 A	LU4A0007	7 A	LU5A0004	4 A
5	LU2A0018	17.5 A	LU4A0009	9 A	LU5A0006	6 A
7.5	LU2A0025	25 A	LU4A0015	15 A	LU5A0010	10 A
10	LU2A0033	33 A	LU4A0018	18 A	LU5A0013	13 A
15	LU2A0047	47 A	LU4A0024	24 A	LU5A0017	17 A
20	LU2A0060	60 A	LU4A0031	31 A	LU5A0022	22 A
25	LU2A0075	75 A	LU4A0039	39 A	LU5A0027	27 A
30	LU2A0085	85 A	LU4A0045	45 A	LU5A0032	32 A
40	LU2A0115	115 A	LU4A0060	60 A	LU5A0041	41 A
50	LU2A0145	145 A	LU4A0075	75 A	LU5A0052	52 A
60	LU2A0180	180 A	LU4A0091	91 A	LU5A0062	62 A
75	LU2A0215	215 A	LU4A0112	112 A	LU5A0077	77 A
100	LU2A0283	283 A	LU4A0150	150 A	LU5A0099	99 A
125	LU2A0346	346 A	LU4A0180	180 A	LU5A0130	180 A
150	LU2A0415	415 A	LU4A0216	216 A	LU5A0172	172 A
200			LU4A0260	260 A	LU5A0200	200 A
250			LU4A0304	304 A		
300			LU4A0370	370 A		
350			LU4A0450	450 A		
500			LU4A0605	605 A		

Model Number Key

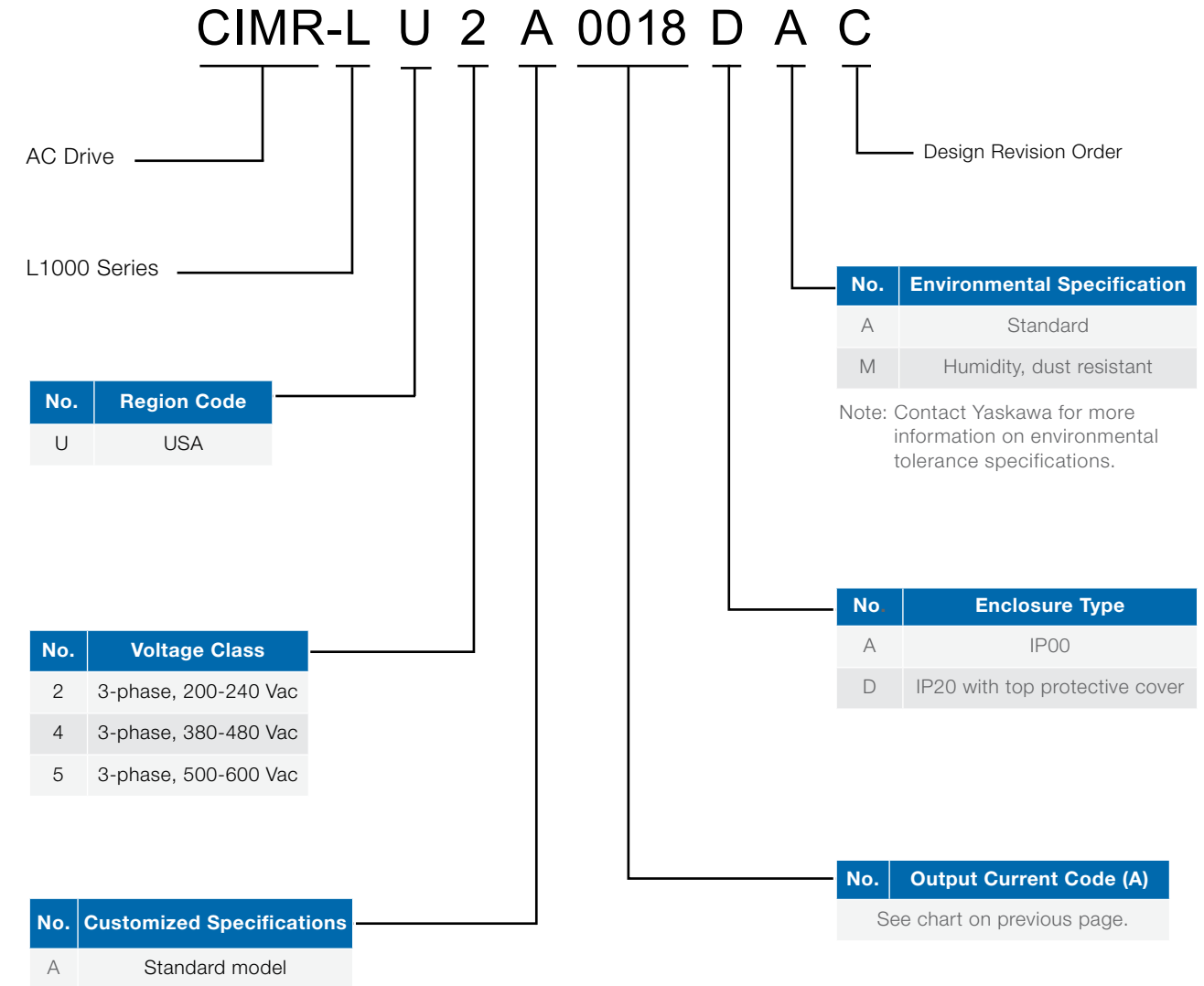

Ratings

200 to 240 VAC (Three-Phase)

Model CIMR-LU2A		0008	0011	0014	0018	0025	0033	0047	0060	0075	0085	0115	0145	0180	0215	0283	0346	0415	
Max. Applicable Motor Cap.	HP	2	3	4	5	7.5	10	15	20	25	30	40	50	60	75	100	125	150	
Output	Rated Output Capacity	kVA	3	4.2	5.3	6.7	9.5	12.6	17.9	23	29	32	44	55	69	82	108	132	158
	Rated Output Current	A	8 ¹	11 ¹	14 ¹	17.5 ¹	25 ¹	33 ¹	47 ¹	60 ¹	75 ¹	85 ¹	115 ¹	145 ²	180 ²	215 ²	283 ²	346 ²	415 ³
Power	Overload Tolerance		150% of rated output current for 60 s																
	Carrier Freq. (User Adjust.)		2 to 15 kHz (parameter setting)										2 to 10 kHz (parameter setting)						
	Max. Output Voltage		Three-phase: 200 to 240 VAC (Proportional to input voltage)																
	Max. Output Frequency		Up to 200 Hz (parameter setting)																
	Rated Voltage/Rated Freq.		Three-phase: 200 to 240 VAC, 50/60 Hz																
	Allowable Volt. Fluctuation		-15% to +10%																
	Allowable Freq. Fluctuation		±5%																
	Harmonic Prev. Reactor		DC Choke Optional										Built-in DC Choke Standard						
	Braking Transistor		Built-in (30% ED, 30 s)										Optional						
	Power Supply	kVA	4.1	5.8	7.8	9.5	14	18	27	36	44	37	51	62	75	91	124	148	180

380 to 480 VAC (Three-Phase)

Model CIMR-LU4A		0005	0006	0007	0009	0015	0018	0024	0031	0039	0045	0060	0075	0091	0112	0150	0180	0216	0260	0304	0370	0450	0605		
Max. Applicable Motor Cap.	HP	2	3	4	5	7.5	10	15	20	25	30	40	50	60	75	100	125	150	200	250	300	350	500		
Output	Rated Output Capacity	kVA	3.7	4.2	5.5	7	11.3	13.7	18.3	24	30	34	48	57	69	85	114	137	165	198	232	282	343	461	
	Rated Output Current	A	4.8 ¹	5.5 ¹	7 ¹	9.2 ¹	14.8 ¹	18 ¹	24 ¹	31 ¹	39 ¹	45 ¹	60 ¹	75 ¹	91 ¹	112 ²	150 ²	180 ²	216 ²	260 ³	304 ³	370 ³	450 ³	605 ³	
Power	Overload Tolerance		150% of rated output current for 60 s																						
	Carrier Freq. (User Adjust.)		2 to 15 kHz (parameter setting)												2 to 10 kHz (parameter setting)										
	Max. Output Voltage		Three-phase: 380 to 480 VAC (Proportional to input voltage)																						
	Max. Output Frequency		Up to 200 Hz (parameter setting)																						
	Rated Voltage/Rated Freq.		Three-phase: 380 to 480 VAC, 50/60 Hz																						
	Allowable Volt. Fluctuation		-15% to +10%																						
	Allowable Freq. Fluctuation		±5%																						
	Harmonic Prev. Reactor		DC Choke Optional												Built-in DC Choke Standard										
	Braking Transistor		Built-in (30% ED, 30 s)												Optional										
	Power Supply	kVA	4.1	5.8	7.8	10	14.6	19.2	28.4	37.5	46.6	39.3	53	64.9	78.6	96	129.9	155	189	227	274	316	375	534	

500 to 600 VAC (Three-Phase)

Model CIMR-LU5A		0003	0004	0006	0010	0013	0017	0022	0027	0032	0041	0052	0062	0077	0099	0130	0172	0200	
Max. Applicable Motor Cap.	HP	2	3	5	7.5	10	15	20	25	30	40	50	60	75	100	125	150	200	
Output	Rated Output Capacity	kVA	3.5	4.1	6.3	9.8	12	17	22	27	32	41	52	62	77	99	129	171	199
	Rated Output Current	A	3.5	4.1	6.3	9.8	12.5	17	22	27	32	41	52	62	77	99	130	172	200
Power	Overload Tolerance		150% of rated output current for 60 s																
	Carrier Freq. (User Adjust.)		2 to 15 kHz (parameter setting)																
	Max. Output Voltage		Three-phase: 500 to 600 VAC (Proportional to input voltage)																
	Max. Output Frequency		Up to 200 Hz (parameter setting)																
	Rated Voltage/Rated Freq.		Three-phase: 500 to 600 VAC, 50/60 Hz																
	Allowable Volt. Fluctuation		-15% to +10%																
	Allowable Freq. Fluctuation		±5%																
	Harmonic Prev. Reactor		DC Choke Optional										Built-in DC Choke Standard						
	Braking Transistor		Built-in (30% ED, 30 s)										Optional						
	Power Supply	kVA	4.1	5.8	9.5	14	18	26	35	43	38	50	62	75	91	123	147	181	261

*1: The accuracy of these values depends on motor characteristics, ambient conditions, and drive settings. Specifications may vary with different motors and with changing motor temperature. Contact Yaskawa for consultation.

*2: Overload protection may be triggered when operating with 150% of the rated output current if the output speed is less than 6 Hz.

*3: Ground protection cannot be provided when the impedance of the ground fault path is too low, or when the drive is powered up while a ground fault is present at the output.

Standard Specifications

Connection Diagram

Common Specifications

Item	Specifications
Control Method	Sine wave PWM (Closed Loop Vector Control, Open Loop Vector Control, V/f Control, PM Flux Vector control)
Frequency Control Range	0.01 to 200 Hz
Frequency Accuracy (Temperature Fluctuation)	Digital reference: $\pm 0.01\%$, -10 to +40°C Analog reference: $\pm 0.1\%$, 25°C $\pm 10^\circ\text{C}$
Frequency Setting Resolution	Digital reference: 0.01 Hz Analog reference: 0.03/60 Hz (11 bit)
Output Speed Resolution	0.001 Hz
Frequency Setting Signal	-10 to +10V, 0 to +10V
Starting Torque *1	200% at 0.3 Hz (Open Loop Vector Control), 200% at 0 rpm (Closed Loop Vector Control, PM Closed Loop Vector Control)
Speed Control Range *1	1:40 (V/f Control) 1:200 (Open Loop Vector Control) 1:1500 (Closed Loop Vector Control, PM Closed Loop Vector Control)
Speed Control Accuracy *1	$\pm 3\%$ (V/f Control) $\pm 0.2\%$ (Open Loop Vector Control at 25°C $\pm 10^\circ\text{C}$) $\pm 0.02\%$ (Closed Loop Vector Control, PM Closed Loop Vector Control at 25°C $\pm 10^\circ\text{C}$)
Speed Response *1	10 Hz (Open Loop Vector Control), 50 Hz (Closed Loop Vector Control, PM Closed Loop Vector Control)
Torque Limit	Vector control allows separate settings in four quadrants
Accel/Decel Ramp	0.01 to 6000.0 s (4 selectable combinations of independent acceleration and deceleration settings)
Braking Torque	Approx. 20% (approx. 125% with dynamic braking resistor option), Models up to CIMR-L□2A0115, 4A0060, and 5A0041 have a built-in transistor
Torque Accuracy	$\pm 5\%$
V/f Characteristics	User programmable
Overload Accuracy	150% of rated output current for 60 s
S-Curve (Jerk) Setting	Starting, acceleration end, deceleration start, leveling, stop setting independently
Main Control Functions	Inertia Compensation, Position Lock at Start and Stop (Anti-Rollback) Function, Overtorque/Undertorque Detection, Torque Limit, Speed Reference, Accel/Decel Switchover, 5-Zone Jerk Settings, Auto-tuning (Stationary and Rotational Motor/Encoder Offset Tuning), Dwell, Cooling Fan On/Off or Temperature Controlled, Slip Compensation, Torque Compensation, DC Injection Braking at Start and Stop, MEMOBUS/Modbus Comm. (RS-422/485 max. 115.2 kbps), Fault Restart, Removable Terminal Block with Parameter Backup Function, High Frequency Injection, Short Floor, Rescue Operation (Light Load Direction Search Function), Inspection Run, Brake Sequence, Motor Temperature PTC Input, Speed Related Parameters with Elevator Units Display, Anti-vibration, etc.
Motor Protection	Electronic thermal motor overload protection
Momentary Overcurrent Protection	Drive stops when output current exceeds 200%
Overload Protection	Drive stops after 60 s at 150% of rated output current *2
Overvoltage Protection	200 V class: Stops when DC bus exceeds approx. 410 V; 400 V class: Stops when DC bus exceeds approx. 820 V 600 V class: Stops when DC bus exceeds approx. 1040 V
Undervoltage Protection	Stops when DC bus voltage falls below the following levels: Three-phase 200 V class: approx. 190 V; Single-phase 200 V class: approx. 160 V; Three-phase 400 V class: approx. 380 V; Three-phase 380 V class: approx. 350 V; Three-phase 600 V class: approx. 475 V
Heatsink Overheat Protection	Protection by thermistor
Braking Resistance Overheat Protection	Overheat sensor for braking resistor
Stall Prevention	Separate settings allowed during acceleration and during run. Enable/disable only during deceleration.
Ground Fault Protection	Protection by electronic circuit *3
Charge LED	Charge LED remains lit until DC bus has fallen below approx. 50 V
Area of Use	Indoors
Ambient Temperature	-10 to 40°C (IP00 enclosure with top protective cover); -10 to 50°C (IP00 enclosure)
Humidity	95% RH or less (non-condensing)
Storage Temperature	-20 to 60°C (short-term temperature during transportation)
Altitude	Up to 1000 meters without derating, up to 3000 meters with derating
Vibration/Shock	10 to 20 Hz: 9.8 m/s ² ; 20 to 55 Hz: 5.9 m/s ² (2A0011 to 2A0180; 4A0007 to 4A0150, 5A0003 to 5A0077) or 2.0 m/s ² (2A0215 to 2A0415, 4A0180 to 4A0605, 5A0130 to 5A0172)
Safety Standard	UL508C, UL, cUL, CE, CSA B44.1, ISO/EN 13849-1 Cat. 3, IEC/EN 61508 SIL2*4
Network Communications	Modbus communications. (RS-422/485 max. 115.2 kbps) standard. Options: CANopen, others
Feedback Devices	Incremental, EnDat, SIN/COS, HIPERFACE
Protection Design	IP00 with top protective cover, IP00

*1: The accuracy of these values depends on motor characteristics, ambient conditions, and drive settings. Specifications may vary with different motors and with changing motor temperature. Contact Yaskawa for consultation.

*2: Overload protection may be triggered when operating with 150% of the rated output current if the output speed is less than 6 Hz.

*3: Ground protection cannot be provided when the impedance of the ground fault path is too low, or when the drive is powered up while a ground fault is present at the output.

*4: Terminals H1, H2, DM+, and DM- on 600V class models are designed to the functionality, but are not certified to insulation coordination: Class 1.

Example: CIMR-LU2A008DAC

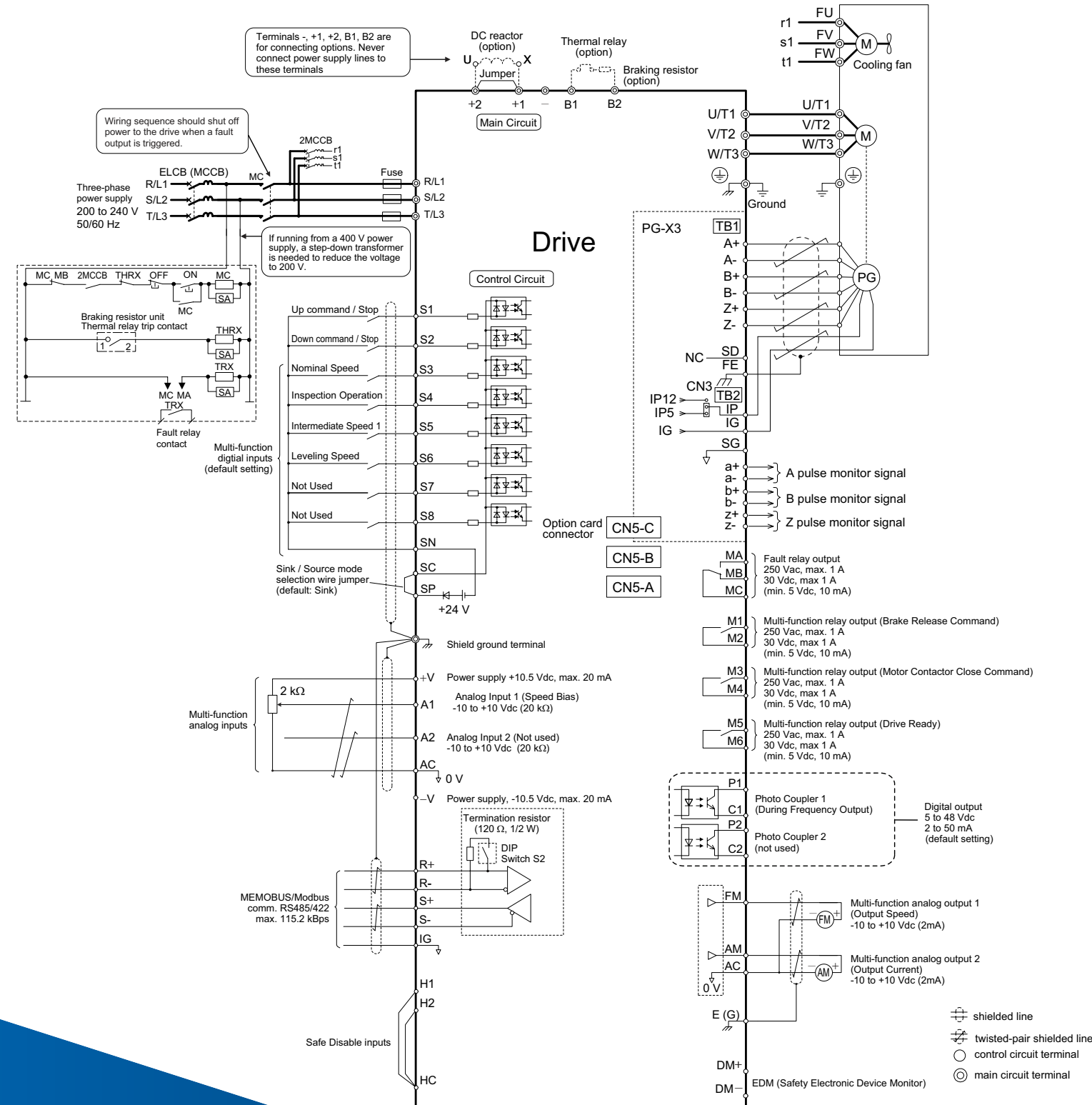

Dimensions

IP00 Enclosure with Top Protective Cover

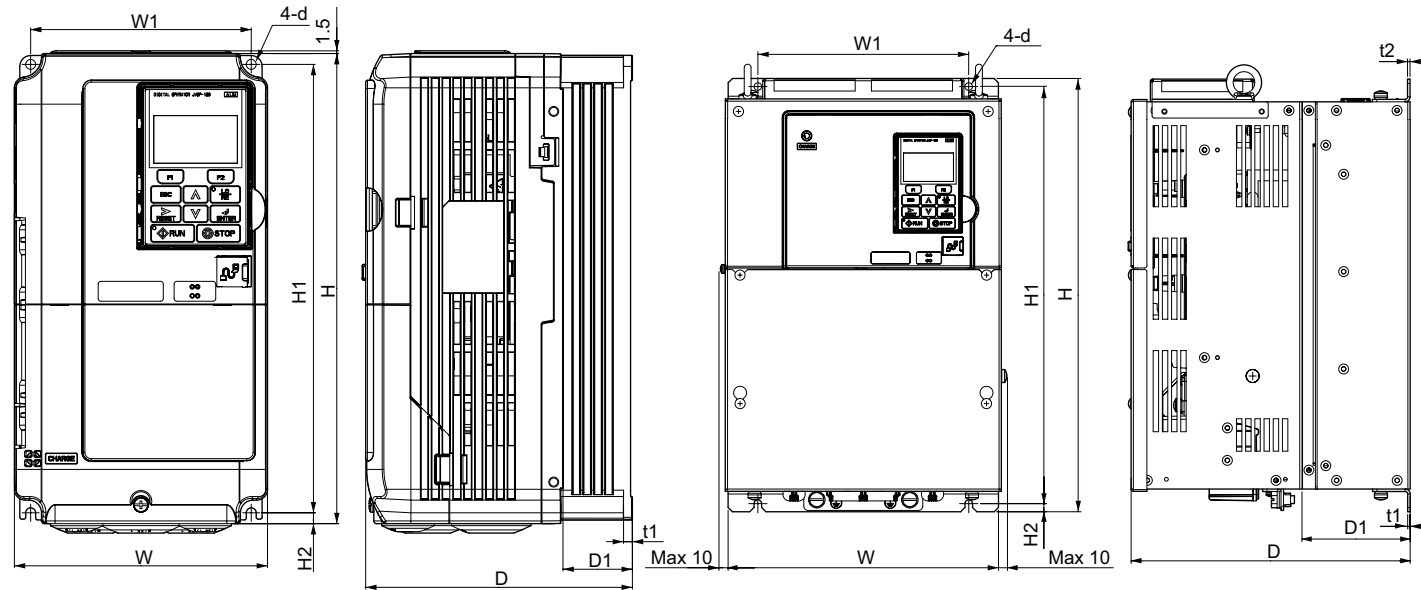

Figure 1

Figure 2

200 V Class Models

Model CIMR-LU□	Dimensions (in.)											Weight (lb)
	Figure	W	H	D	W1	H1	H2	D1	t1	t2	d	
2A0008	1	5.5	10.2	5.8	4.8	9.8	0.2	1.5	0.2	-	M5	7.1
2A0011		5.5	10.2	5.8	4.8	9.8	0.2	1.5	0.2	-	M5	7.1
2A0014		5.5	10.2	6.5	4.8	9.8	0.2	2.2	0.2	-	M5	7.7
2A0018		5.5	10.2	6.5	4.8	9.8	0.2	2.2	0.2	-	M5	7.7
2A0025		5.5	10.2	6.6	4.8	9.8	0.2	2.2	0.2	-	M5	8.8
2A0033		5.5	10.2	6.6	4.8	9.8	0.2	2.2	0.2	-	M5	8.8
2A0047		7.1	11.8	7.4	6.3	11.2	0.3	3.0	0.2	-	M5	12.3
2A0060		8.7	13.8	7.8	7.6	13.2	0.3	3.1	0.2	-	M6	19.2
2A0075	2	8.7	14.4	7.8	7.6	13.2	0.3	3.1	0.2	-	M6	21.4
2A0085		9.8	15.7	10.2	7.7	15.2	0.3	3.9	0.1	0.1	M6	46.3
2A0115		10.8	17.7	10.2	8.7	17.1	0.3	3.9	0.1	0.1	M6	55.1
2A0145		12.8	21.7	11.1	10.2	21.1	0.3	4.3	0.1	0.1	M6	81.6
2A0180		12.8	21.7	11.1	10.2	21.1	0.3	4.3	0.1	0.1	M6	83.8

400 V Class Models

Model CIMR-LU□	Dimensions (in.)											Weight (lb)
	Figure	W	H	D	W1	H1	H2	D1	t1	t2	d	
4A0005	1	5.5	10.2	5.8	4.8	9.8	0.2	1.5	0.2	-	M5	7.1
4A0006		5.5	10.2	6.5	4.8	9.8	0.2	2.2	0.2	-	M5	7.5
4A0007		5.5	10.2	6.5	4.8	9.8	0.2	2.2	0.2	-	M5	7.7
4A0009		5.5	10.2	6.5	4.8	9.8	0.2	2.2	0.2	-	M5	7.7
4A0015		5.5	10.2	6.6	4.8	9.8	0.2	2.2	0.2	-	M5	8.6
4A0018		5.5	10.2	6.6	4.8	9.8	0.2	2.2	0.2	-	M5	8.6
4A0024		7.1	11.8	6.6	6.3	11.2	0.3	2.2	0.2	-	M5	11.9
4A0031		7.1	11.8	7.4	6.3	11.2	0.3	3.0	0.2	-	M5	12.6
4A0039	2	8.7	13.8	7.8	7.6	13.2	0.3	3.1	0.2	-	M6	18.3
4A0045		9.8	15.7	10.2	7.7	15.2	0.3	3.9	0.1	0.1	M6	46.3
4A0060		10.8	17.7	10.2	8.7	17.1	0.3	3.9	0.1	0.1	M6	55.1
4A0075		12.8	20.1	10.2	10.2	19.5	0.3	4.1	0.1	0.1	M6	79.4
4A0091		12.8	20.1	10.2	10.2	19.5	0.3	4.1	0.1	0.1	M6	79.4
4A0112		12.8	21.7	11.1	10.2	21.1	0.3	4.3	0.1	0.1	M6	90.4
4A0150		12.8	21.7	11.1	10.2	21.1	0.3	4.3	0.1	0.1	M6	92.6

600 V Class Models

Model CIMR-L□	Dimensions (in.)											Weight (lb)
	Figure	W	H	D	W1	H1	H2	D1	t1	t2	d	
5A0003	1	5.5	10.2	5.8	4.8	9.8	0.2	1.5	0.2	-	M5	7.1
5A0004		5.5	10.2	6.5	4.8	9.8	0.2	2.2	0.2	-	M5	7.7
5A0006		5.5	10.2	6.5	4.8	9.8	0.2	2.2	0.2	-	M5	7.7
5A0010		5.5	10.2	6.6	4.8	9.8	0.2	2.2	0.2	-	M5	8.6
5A0013		7.1	11.8	7.4	6.3	11.2	0.3	3.0	0.2	-	M5	12.6
5A0017		7.1	11.8	7.4	6.3	11.2	0.3	3.0	0.2	-	M6	12.6
5A0022		8.7	13.8	7.8	7.6	13.2	0.3	3.1	0.2	-	M6	18.3
5A0027		8.7	13.8	7.8	7.6	13.2	0.3	3.1	0.2	-	M6	18.3
5A0032	2	10.8	17.7	10.2	8.7	17.1	0.3	3.9	0.1	0.1	M6	55.1
5A0041		10.8	17.7	10.2	8.7	17.1	0.3	3.9	0.1	0.1	M6	55.1
5A0052		12.8	21.7	11.1	10.2	21.1	0.3	4.3	0.1	0.1	M6	90.4
5A0062		12.8	21.7	11.1	10.2	21.1	0.3	4.3	0.1	0.1	M6	90.4
5A0077		12.8	21.7	11.1	10.2	21.1	0.3	4.3	0.1	0.1	M6	90.4
5A0099		17.7	27.8	13.0	12.8	26.8	0.5	5.1	0.1	0.1	M10	177.5

Dimensions

IP00 Enclosure Drive

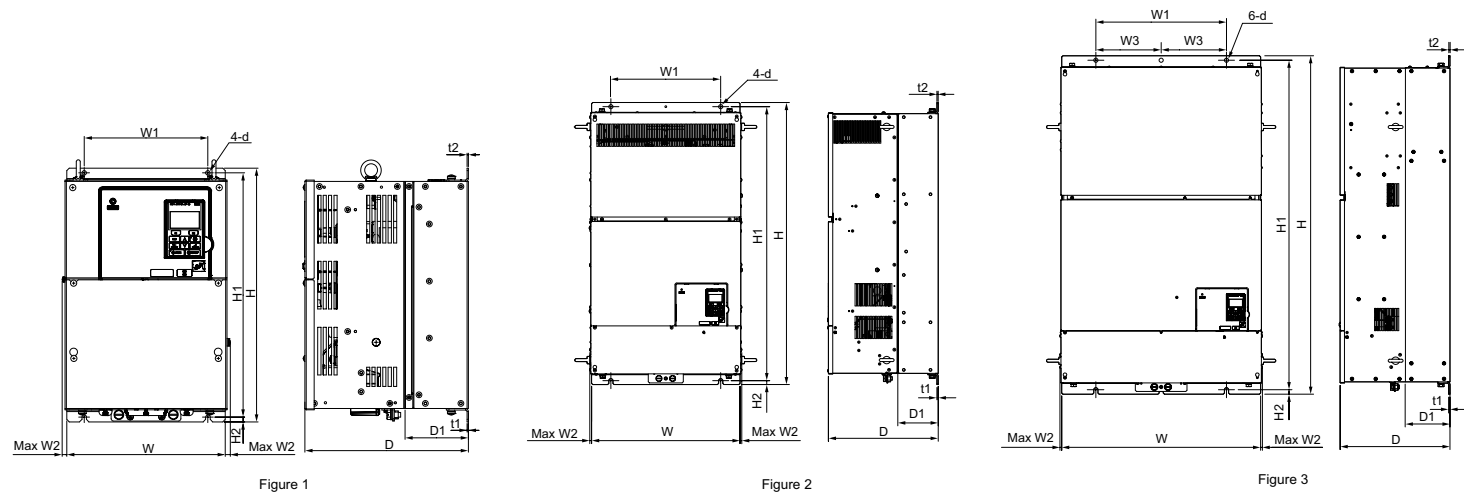

200 V Class Models

Model CIMR-LU□	Dimensions (in.)											Weight (lb)
	Figure	W	H	D	W1	H1	H2	D1	t1	t2	d	
2A0215	1	17.7	27.8	13.0	12.8	26.8	0.5	5.1	0.1	0.1	M10	167.6
2A0283		17.7	27.8	13.0	12.8	26.8	0.5	5.1	0.1	0.1	M10	176.4
2A0346		19.7	31.5	13.8	14.6	30.4	0.5	5.1	0.2	0.2	M12	216.1
2A0415		19.7	31.5	13.8	14.6	30.4	0.5	5.1	0.2	0.2	M12	218.3

400 V Class Models

Model CIMR-LU□	Dimensions (in.)											Weight (lb)
	Figure	W	H	D	W1	H1	H2	D1	t1	t2	d	
4A0180	1	17.7	27.8	13.0	12.8	26.8	0.5	5.1	0.1	0.1	M10	174.2
4A0216		19.7	31.5	13.8	14.6	30.4	0.5	5.1	0.2	0.2	M12	211.6
4A0260		19.7	31.5	13.8	14.6	30.4	0.5	5.1	0.2	0.2	M12	224.9
4A0304		19.7	31.5	13.8	14.6	30.4	0.5	5.1	0.2	0.2	M12	235.9
4A0370	2	19.7	37.4	14.6	14.6	36.3	0.5	5.3	0.2	0.2	M12	275.6
4A0450	3	26.4	44.9	14.6	17.3	43.7	0.5	5.9	0.2	0.2	M12	476.2
4A0605		26.4	44.9	14.6	17.3	43.7	0.5	5.9	0.2	0.2	M12	487.2

600 V Class Models

Model CIMR-LU□	Dimensions (in.)											Weight (lb)
	Figure	W	H	D	W1	H1	H2	D1	t1	t2	d	
5A0130	2	17.7	27.8	13.0	12.8	26.8	0.5	5.1	0.1	0.1	M10	174.2
5A0172		19.7	31.5	13.8	14.6	30.4	0.5	5.1	0.2	0.2	M12	235.9
5A0200	3	19.7	31.5	13.8	14.6	30.4	0.5	5.1	0.2	0.2	M12	235.9

Drive Watt Loss Data

200 V Class Models

Model CIMR-LU	Carrier Frequency: 8 kHz			
	Rated Amps (A)	Heatsink Loss (W)	Interior Unit Loss (W)	Total Loss (W)
2A0008	8.0 ^{*1}	43	52	95
2A0011	11.0 ^{*1}	64	58	122
2A0014	14.0 ^{*1}	77	60	137
2A0018	17.5 ^{*1}	101	68	169
2A0025	25.0 ^{*1}	195	93	287
2A0033	33.0 ^{*1}	214	105	319
2A0047	47.0 ^{*1}	281	130	411
2A0060	60.0 ^{*1}	395	163	558
2A0075	75.0 ^{*1}	460	221	681
2A0085	85.0 ^{*1}	511	211	722
2A0115	115.0 ^{*1}	663	250	913
2A0145	145.0 ^{*2}	816	307	1123
2A0180	180.0 ^{*2}	977	379	1355
2A0215	215.0 ^{*2}	1515	467	1981
2A0283	283.0 ^{*2}	1937	588	2524
2A0346	346.0 ^{*2}	2564	783	3347
2A0415	415.0 ^{*2}	2673	955	3627

400 V Class Models

Model CIMR-LU	Carrier Frequency: 8 kHz			
	Rated Amps (A)	Heatsink Loss (W)	Interior Unit Loss (W)	Total Loss (W)
4A0009	9.2 ^{*1}	69	61	130
4A0015	14.8 ^{*1}	136	86	222
4A0018	18.0 ^{*1}	150	97	247
4A0024	24.0 ^{*1}	208	116	324
4A0031	31.0 ^{*1}	263	141	404
4A0039	39.0 ^{*1}	330	180	510
4A0045	45.0 ^{*1}	349	170	519
4A0060	60.0 ^{*1}	485	218	702
4A0075	75.0 ^{*1}	564	254	818
4A0091	91.0 ^{*1}	723	299	1022
4A0112	112.0 ^{*1}	909	417	1325
4A0150	150.0 ^{*1}	1341	581	1921
4A0180	180.0 ^{*1}	1772	541	2313
4A0216	216.0 ^{*1}	2361	716	3076
4A0260	260.0 ^{*2}	2391	787	3178
4A0304	304.0 ^{*2}	3075	985	4060
4A0370	370.0 ^{*2}	3578	1164	4742
4A0450	450.0 ^{*3}	3972	1386	5358
4A0605	605.0 ^{*3}	4191	1685	5875

*1: Value assumes the carrier frequency is set to 8 kHz.

*2: Value assumes the carrier frequency is set to 5 kHz.

*3: Value assumes the carrier frequency is set to 3 kHz.

Drive Watt Loss Data

600 V Class Models

Model CIMR-L□	Carrier Frequency: 8 kHz			
	Rated Amps (A)	Heatsink Loss (W)	Interior Unit Loss (W)	Total Loss (W)
5A0003	3.5 ^{*1}	54	28	82
5A0004	4.1 ^{*1}	53	27	80
5A0006	6.3 ^{*1}	79	36	115
5A0010	9.8 ^{*1}	111	50	160
5A0013	12.5 ^{*1}	145	68	212
5A0017	17.0 ^{*1}	204	81	285
5A0022	22.0 ^{*1}	267	114	381
5A0027	27.0 ^{*1}	333	132	465
5A0032	32.0 ^{*1}	406	128	534
5A0041	41.0 ^{*1}	527	161	689
5A0052	52.0 ^{*1}	1272	355	1607
5A0062	62.0 ^{*1}	1457	380	1837
5A0077	77.0 ^{*2}	1267	352	1619
5A0099	99.0 ^{*3}	1328	422	1750
5A0130	130.0 ^{*3}	1638	508	2146
5A0172	172.0 ^{*3}	2114	648	2762
5A0200	200.0 ^{*3}	2526	896	3422

*1: Value assumes the carrier frequency is set to 8 kHz.

*2: Value assumes the carrier frequency is set to 5 kHz.

*3: Value assumes the carrier frequency is set to 3 kHz.

Options

Name	Purpose	Model
AC Reactors or DC Link Chokes	Reduces Harmonics	For detailed information contact Yaskawa.
Analog Input	Enables high-precision and high-resolution analog speed reference setting. • Input signal level: -10 to +10 Vdc (20 kΩ) 4 to 20 mA (500 Ω) • Input channels: 3 channels, DIP switch for input voltage/input current selection • Input resolution: Input voltage 13 bit signed (1/8192) Input current 1/6554	AI-A3
Digital Input	Enables 16-bit digital speed reference setting. • Input signal: 16 bit binary, 2 digit BCD + sign signal + set signal • Input voltage: +24 V (isolated) • Input current: 8 mA Selectable Parameter: 8 bit, 12 bit, 16 bit	DI-A3
CANopen Communications Interface	Used for running or stopping the drive, setting or referencing parameters and monitoring output speed, output current, or similar items through CANopen communication with the host controller.	SI-S3
Analog Monitor	Outputs analog signal for monitoring drive output state (output speed, output current etc.). • Output resolution: 11 bit signed (1/2048) • Output voltage: -10 to +10 Vdc (non-isolated) • Output channels: 2 channels	AO-A3
Digital Output	Outputs isolated type digital signal for monitoring drive run state (alarm signal, zero speed detection, etc.). Output channel: Photocoupler 6 channels (48 V, 50 mA or less) Relay contact output 2 channels 250 Vac, 1 A or less 30 Vdc, 1 A or less	DO-A3
Open Collector PG Interface	For control modes requiring a PG encoder for motor feedback: • Phase A, B, and Z pulse (3-phase) inputs (complementary type) • PG frequency range: Approx. 50 kHz max. • Power supply output for PG: +24 V, max. current 30 mA • Pulse monitor output: Open collector, +24 V, max. current 30 mA • Power supply output for PG: +12 V, max. current 200 mA	PG-B3
Line Driver PG Interface	For control modes requiring a PG encoder for motor feedback: • Phase A, B, and Z pulse (differential pulse) inputs (RS-422) • PG frequency range: up to 300 kHz (approx.) • Pulse monitor output: RS-422 • Power supply output for PG: +5 V or +12 V, max. current 200 mA	PG-X3
Absolute Encoder	EnDat Motor Feedback	PG-F3 (EnDat 2.1/01, 2.2/01, 2.2/22, HIPERFACE)
Absolute Encoder	HEIDENHAIN Motor Feedback	PG-E3 (HEIDENHAIN ERN1387/487)
LED Operator	Easy long distance reading	JVOP-182
Braking Resistor	Used to shorten the deceleration time by dissipating regenerative energy	For detailed information contact Yaskawa.
Braking Resistor Unit	Shortened deceleration time results when used with a Braking Resistor Unit. For units above 40 HP	CDBR series
24 V Power Supply	Provides power supply for the control circuit and option boards. Note: Parameter settings cannot be changed when the drive is operating solely from this power supply.	PS-A10H PS-A10L
USB Copy Unit (RJ-45/USB compatible plug)	• Adapter for connecting the drive to the USB port of a PC • Can copy parameter settings easily and quickly to be later transferred to another drive.	JVOP-181
LCD Operator Extension Cable	Extension cable for connecting the LCD operator.	WV001: 1 m WV003: 3 m

Note: Contact the manufacturer specified for availability and specifications of non-Yaskawa products.

Noise Filter (EMC Filter)

The drive should be installed with the EMC filters listed below in order to comply with the EN61800-3/EN12015 requirements.

If the safe disable function of the drive is part of the safety concept of a machine or installation and used for a safe stop according to EN60204-1, stop category 0, use only filters manufactured by Schaffner as listed below. This also applies when using the safe disable function in one motor contactor installations.

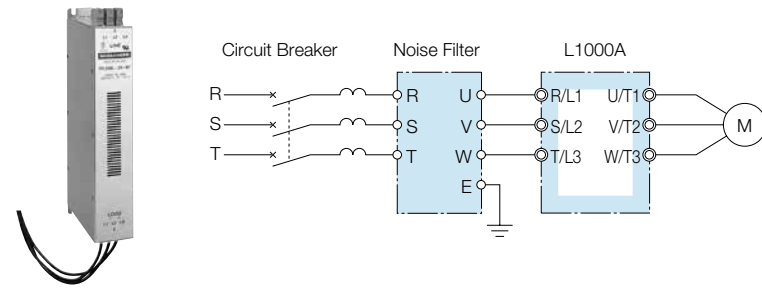

Note: Only a single noise filter is required if the filter is made by Schaffner EMC.

Dimensional Diagrams

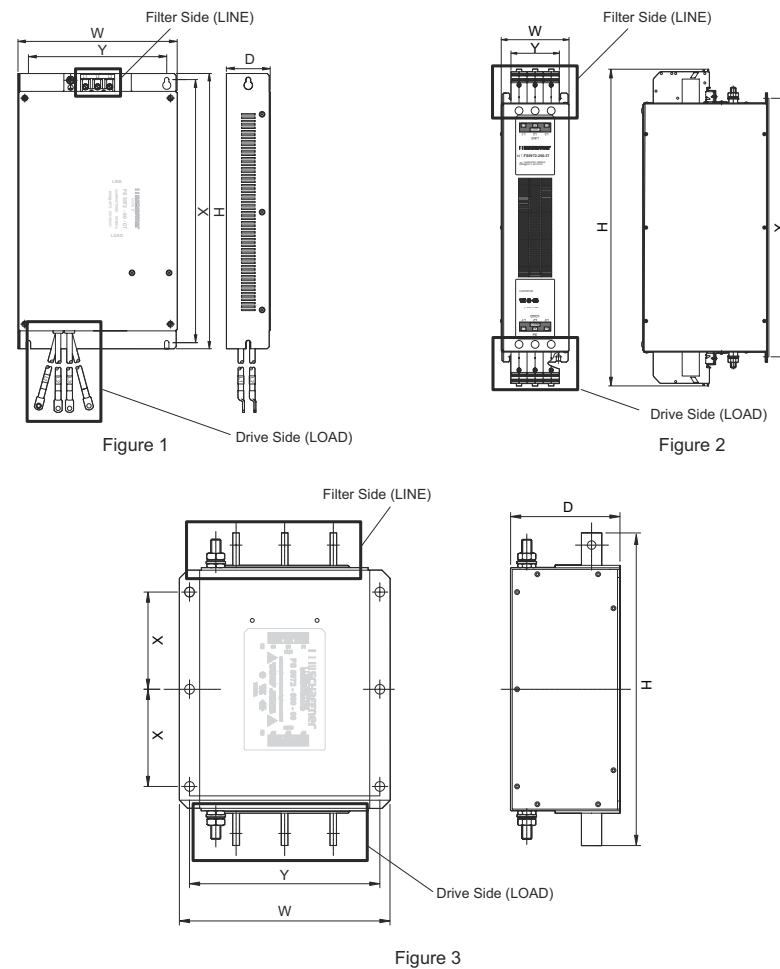

Model CIMR-LU□	Filter Data (Manufacturer: Schaffner)				Dimensions	
	Model Number	Rated Current (A)	Weight (lb)	Figure (previous page)	W x D x H (in.)	Y x X (in.)
Three-Phase 200 V Class						
2A0008	FS5972-10-07	10	2.6	1	5.6 x 1.8 x 13.0	4.5 x 12.3
2A0011	FS5972-18-07	18	3.7		9.3 x 2.6 x 16.1	4.5 x 12.3
2A0014		35	4.6		3.5 x 5.9 x 13.0	6.9 x 13.2
2A0018	FS5972-60-07	60	8.8		4.7 x 6.7 x 17.8	8.1 x 15.4
2A0025		100	7.5		3.5 x 5.9 x 13.0	2.6 x 10.0
2A0033	FS5972-100-35	170	13.2	2	4.7 x 6.7 x 17.8	4.0 x 14.4
2A0047		250	25.8		5.1 x 9.4 x 24.0	3.5 x 19.6
2A0060	FS5972-250-37	410	23.1	3	10.2 x 4.5 x 15.2	9.3 x 4.7
2A0075		600	24.3		10.2 x 5.3 x 15.2	9.3 x 4.7
2A0085	FS5972-410-99	250	25.8		3	10.2 x 4.5 x 15.2
2A0115		410	23.1	10.2 x 5.3 x 15.2		9.3 x 4.7
2A0145	FS5972-600-99	600	24.3	3	10.2 x 4.5 x 15.2	9.3 x 4.7
2A0180		800	31.5		11.8 x 6.3 x 15.2	8.3 x 10.8
Three-Phase 400 V Class						
4A0005	FS5972-10-07	10	42.6	1	5.6 x 1.8 x 13.0	4.5 x 12.3
4A0006		18	3.7		5.6 x 1.8 x 13.0	4.5 x 12.3
4A0007	FS5972-18-07	35	4.6		8.1 x 2.0 x 14.0	6.9 x 13.2
4A0015		60	8.8		9.3 x 2.6 x 16.1	8.1 x 15.4
4A0018	FS5972-60-07	100	7.5		2	3.5 x 5.9 x 13.0
4A0024		170	13.2	4.7 x 6.7 x 17.8		4.0 x 14.4
4A0031	FS5972-170-40	250	25.8	3	5.1 x 9.4 x 24.0	3.5 x 19.6
4A0039		410	23.1		10.2 x 4.5 x 15.2	9.3 x 4.7
4A0045	FS5972-250-37	600	24.3		3	10.2 x 4.5 x 15.2
4A0060		800	31.5	11.8 x 6.3 x 15.2		8.3 x 10.8
4A0091	FS5972-410-99	410	23.1	3	10.2 x 4.5 x 15.2	9.3 x 4.7
4A0112		600	24.3		10.2 x 5.3 x 15.2	4.7 x 9.3
4A0150	UF1000032	800	31.5	3	11.8 x 6.3 x 15.2	8.3 x 10.8
4A0180		UF1000033	800		31.5	11.8 x 6.3 x 15.2

Dynamic Brake Module



The L1000A includes a built-in braking transistor in drive units of 200 V and 400 V class up to 40 HP. For L1000A drives above 40 HP with braking torque requirements, a dynamic brake module is available as an option. Please contact a Yaskawa representative for further information on braking resistors. The table below indicates the recommended dynamic brake module and the resistor specification.

Max. Applicable Motor (HP)	L1000A Model CIMR-LU□	Braking Module		Braking Resistor Unit			Min.* Connection Resistance (Ω)
		Model CDBR-□□□□□	Qty.	Resistor Specs. (per unit)	Qty.	Braking Torque(%) (10% ED)	
Three Phase 200 V Class							
2	2A0008	Built-in		260 W 70 Ω	1	120	16
3	2A0011	Built-in		260 W 70 Ω	1	120	16
4	2A0014	Built-in		390 W 40 Ω	1	150	16
5	2A0018	Built-in		390 W 40 Ω	1	125	16
7.5	2A0025	Built-in		520 W 30 Ω	1	115	16
10	2A0033	Built-in		780 W 20 Ω	1	125	9.6
15	2A0047	Built-in		2400 W 13.6 Ω	1	125	9.6
20	2A0060	Built-in		3000 W 10 Ω	1	125	9.6
25	2A0075	Built-in		3000 W 10 Ω	1	100	9.6
30	2A0085	Built-in		4800 W 6.8 Ω	1	125	6.4
40	2A0115	Built-in		4800 W 6.8 Ω	1	90	6.4
50	2A0145	20370D	2	3000 W 10 Ω	2	100	9.6
60	2A0180	20370D	2	4800 W 6.8 Ω	2	120	6.4
75	2A0215	20370D	2	4800 W 6.8 Ω	2	100	6.4
100	2A0283	21100D	1	4800 W 6.8 Ω	3	110	1.6
125	2A0346	21100D	1	4800 W 6.8 Ω	4	120	1.6
150	2A0415	21100D	1	4800 W 6.8 Ω	5	100	1.6
Three Phase 400 V Class							
2	4A0005	Built-in		390 W 150 Ω	1	150	32
3	4A0007	Built-in		390 W 150 Ω	1	150	32
4	4A0009	Built-in		390 W 150 Ω	1	135	32
7.5	4A0015	Built-in		520 W 100 Ω	1	135	32
10	4A0018	Built-in		780 W 75 Ω	1	130	32
15	4A0024	Built-in		1040 W 50 Ω	1	135	20
20	4A0031	Built-in		1560 W 40 Ω	1	125	20
25	4A0039	Built-in		4800 W 32 Ω	1	125	19.2
30	4A0045	Built-in		4800 W 27.2 Ω	1	125	19.2
40	4A0060	Built-in		6000 W 20 Ω	1	125	19.2
50	4A0075	40450D	1	9600 W 16 Ω	1	125	12.8
60	4A0091	40450D	1	9600 W 13.6 Ω	1	125	12.8
75	4A0112	40450D	2	6000 W 20 Ω	2	135	19.2
100	4A0150	40450D	2	9600 W 13.6 Ω	2	145	12.8
125	4A0180	40450D	2	9600 W 13.6 Ω	2	120	12.8
150	4A0216	40450D	3	6000 W 20 Ω	3	100	3.2
200	4A0260	42200D	1	9600 W 13.6 Ω	4	150	3.2

Max. Applicable Motor (HP)	L1000A Model CIMR-LU□	Braking Module		Braking Resistor Unit			Min.* Connection Resistance (Ω)
		Model CDBR-□□□□□	Qty.	Resistor Specs. (per unit)	Qty.	Braking Torque(%) (10% ED)	
Three Phase 600 V Class							
2	5A0003	Built-in		290 W 400 Ω	1	100	150
3	5A0004	Built-in		235 W 350 Ω	1	100	150
5	5A0006	Built-in		560 W 150 Ω	1	100	130
7.5	5A0010	Built-in		920 W 120 Ω	1	156	90
10	5A0013	Built-in		1200 W 78 Ω	1	136	65
15	5A0017	Built-in		1670 W 59 Ω	1	102	44
20	5A0022	Built-in		2210 W 47 Ω	1	102	32
25	5A0027	Built-in		2760 W 39 Ω	1	101	29
30	5A0032	Built-in		3310 W 29 Ω	1	102	15
40	5A0041	Built-in		4320 W 23 Ω	1	102	15
50	5A0052	50370D	2	2720 W 27.2 Ω	2	101	23.8
60	5A0062	50370D	2	2720 W 27.2 Ω	2	112	23.8
75	5A0077	51100D	1	7100 W 10.5 Ω	1	94	9.5
100	5A0099	53000D	1	10880 W 8.4 Ω	1	113	3.8
125	5A0130	53000D	1	13540 W 6.4 Ω	1	112	3.8
150	5A0172	53000D	1	14060 W 5.2 Ω	1	90	3.8

* The value shown for the minimum connection resistance is that for a single braking unit. Select a resistance value higher than the connectable resistance value and enough to generate the required braking torque.

Dynamic Braking Module Dimensions (in.)

Models: CDBR-20220D, -40300D, -40450D

Model: CDBR-21100D

Model: CDBR-42200D, -51100D*, -53000D

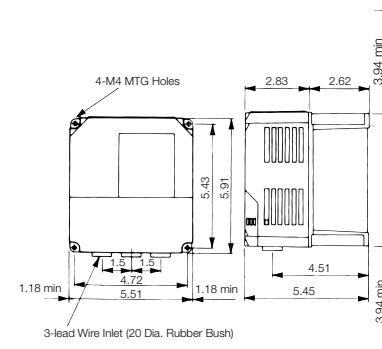

Weight: 4 lb

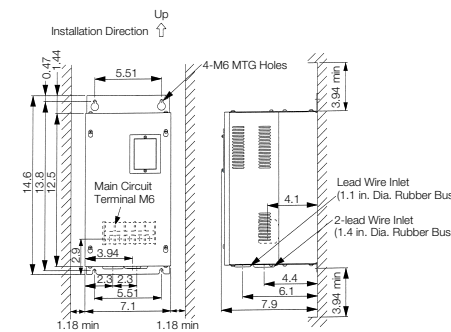

Weight: 18.7 lb

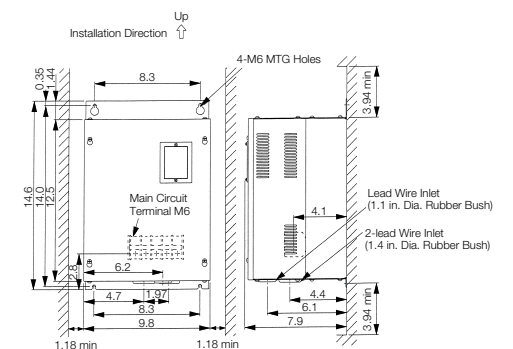

*1 - Width = 8.66in
- Mounting width = 7.09in
Weight: 26.4 lb

Model: CDBR-□□□□□	20220D	20370D	21100D	40300D	40450D	42200D	50370D	51100D	53000D
Heat Loss (W)	27	38	64	54	59	71	22	53	116

24 VDC Power Supply

The 24 V Power Supply Option maintains drive control circuit power in the event of a main power outage. The control circuit keeps the network communications and I/O data operational in the event of a power outage. It supplies external power to the control circuit only.

Model	Code No.
200 V Class: PS-A10L	PS-A10L
400 and 600 V Class: PS-A10H	PS-A10H

Note: Parameter settings cannot be changed when the drive is operating solely from this power supply.

Connection Diagram

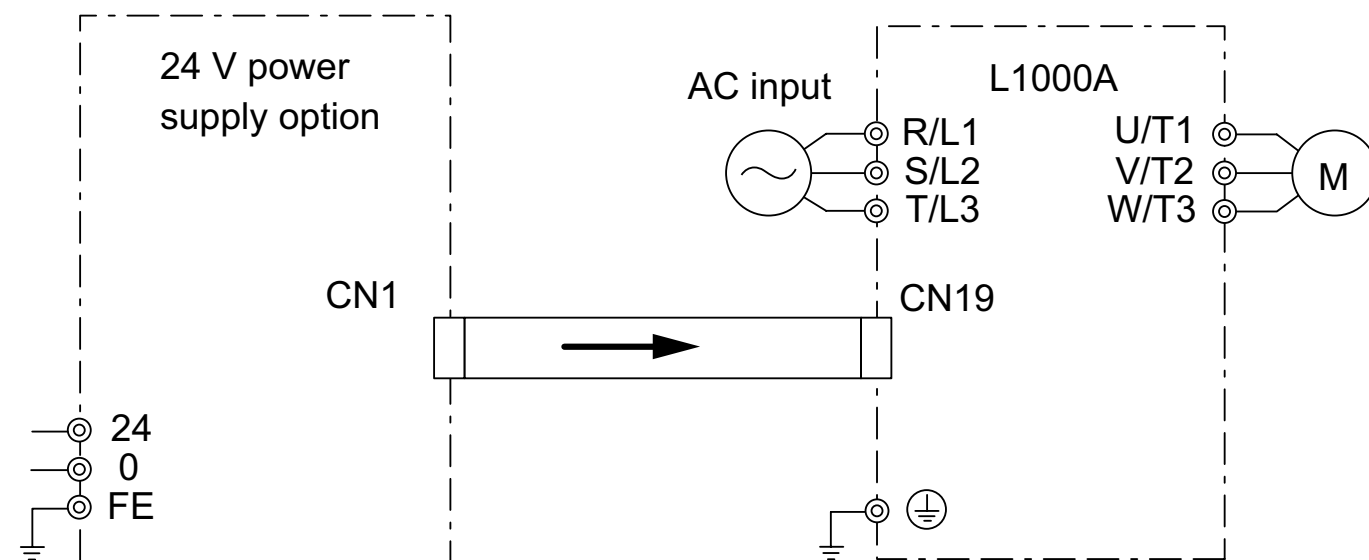

USB Copy Unit

Model JVOP-181

Connection



Model	Description
JVOP-181	USB Copy Unit with RJ-45 Cable and USB Cable

Specifications

Item	Specifications
Port	LAN (RJ-45) USB (Ver.2.0 compatible)
Power Supply	Supplied from a PC or the drive
Operating System	Windows 2000/XP
Memory	Memorizes the parameters for one drive.
Dimensions	1.2 (W) × 3.5 (H) × 0.8 (D) in.
Accessories	RJ-45 Cable (3.3 ft), USB Cable(1 ft)

Notes: 1. Drives must have identical software versions to copy parameter settings.
2. Requires a USB driver.
3. Parameter copy function disabled when connected to a PC.

R1000 Converter

R1000 Converter (Line Regeneration Unit)



The R1000 Converter is a high-performance line regeneration unit for elevator applications that require a high-demand braking cycle. The R1000 is an excellent, competitive solution that takes excess regenerative energy from the driven motor and supplies it to the incoming AC power source. The R1000 is wired in parallel with the adjustable frequency drive and can be independently sized to suit the projected regenerative load.

In elevator applications, the R1000 is a cost-competitive alternative to dynamic braking resistors, especially when energy savings is considered. Dynamic Braking resistors simply dissipate (waste) the regenerated energy. The R1000 returns the regenerated energy back to the power grid, reducing the total energy consumption. Payback for high duty cycle applications is typically less than a year with the R1000.

The R1000 includes display monitors (i.e., power, operating time, and others). It mounts inside the panel with the drive, unlike braking resistors which must be mounted externally because of heavy heat generation and large footprints. It is also pre-engineered for heavy duty cycle ratings. Additional configurations are available. Consult the factory.

R1000 Connection Diagram

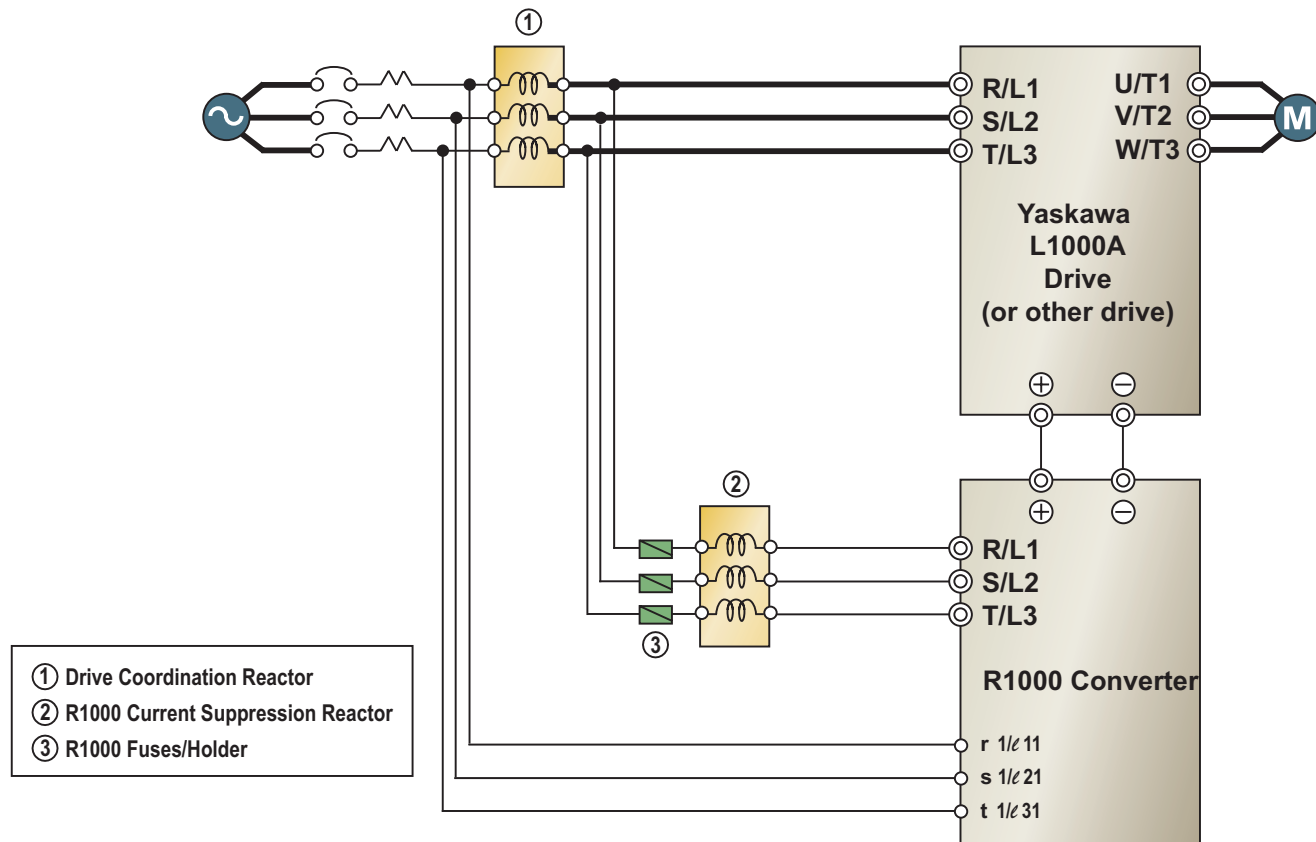

Regenerative System Components

Max. Applicable Motor (HP)	L1000 Model		R1000 Regen Unit			Suppression Reactor	Coordination Reactor	Fuses (Qty 3 Req'd)	Fuse Holder	
	Model CIMR-LU	Model CIMR-RU	Dimensions (in)			Model No.	Model No.	Model No.	Qty	Model No.
			H	W	D					
200V Class										
5	2A0018	2A03P5FAA	11.8	5.5	6.6	05P00620-0134	05P00620-0136	FU-002031	1	FU-002055
7.5	2A0025	2A0005FAA	11.8	5.5	6.6	URX000083	05P00620-0138	FU-002031	1	FU-002055
10	2A0033	2A0007FAA	11.8	5.5	6.6	URX000083	05P00620-0044	FU-002032	1	FU-002055
15	2A0047	2A0010FAA	13.4	7.1	7.4	05P00620-0044	05P00620-0140	UFU000153	3	FU-002082
20	2A0060	2A0014FAA	13.4	7.1	7.4	05P00620-0141	05P00620-0141	UFU000479	3	FU-002082
25	2A0075	2A0017FAA	15.8	8.7	7.8	05P00620-0143	05P00620-0143	UFU000154	3	FU-002083
30	2A0085	2A0020FAA	15.8	8.7	7.8	URX000085	05P00620-0143	UFU000155	3	FU-002083
40	2A0115	2A0028FAA	15.8	8.7	7.8	URX000085	05P00620-0013	UFU000156	3	FU-002083
50	2A0145	2A0035AAA	17.7	10.8	10.2	05P00620-0064	05P00620-0070	UFU000156	3	FU-002083
60	2A0180	2A0053AAA	21.7	12.8	11.1	URX000086	05P00620-0146	UFU000494	3	FU-002083
75	2A0215	2A0053AAA	21.7	12.8	11.1	URX000086	05P00620-0146	UFU000494	3	FU-002083
100	2A0283	2A0073AAA	27.8	17.7	13	URX000175	URX000175	UFU000375	3	UFU000378
125	2A0346	2A0105AAA	31.5	19.7	13.8	URX000178	URX000181	UFU000376	3	UFU000122
150	2A0415	2A0105AAA	31.5	19.7	13.8	URX000178	URX000181	UFU000376	3	UFU000122
400V Class										
5	4A0009	4A03P5FAA	11.8	5.5	6.6	05P00620-0025	05P00620-0133	FU-002030	1	FU-002055
7.5	4A0015	4A0005FAA	11.8	5.5	6.6	05P00620-0133	05P00620-0135	FU-002030	1	FU-002055
10	4A0018	4A0007FAA	11.8	5.5	6.6	05P00620-0135	05P00620-0137	FU-002030	1	FU-002055
15	4A0024	4A0010FAA	13.4	7.1	7.4	05P00620-0137	05P00620-0138	FU-002032	1	FU-002055
20	4A0031	4A0014FAA	13.4	7.1	7.4	URX000083	05P00620-0139	FU-002032	1	FU-002055
25	4A0039	4A0017FAA	15.8	8.7	7.8	05P00620-0044	05P00620-0139	FU-000783	3	FU-002082
30	4A0045	4A0020FAA	15.8	8.7	7.8	05P00620-0049	05P00620-0049	FU-000783	3	FU-002082
40	4A0060	4A0028FAA	15.8	8.7	7.8	05P00620-0142	05P00620-0142	UFU000480	3	FU-002082
50	4A0075	4A0035AAA	17.7	10.8	10.2	05P00620-0144	05P00620-0144	FU-000806	3	FU-002084
60	4A0091	4A0043AAA	17.7	10.8	10.2	05P00620-0143	05P00620-0144	FU-000807	3	FU-002084
75	4A0112	4A0053AAA	21.7	12.8	11.1	URX000085	05P00620-0145	FU-000809	3	FU-002084
100	4A0150	4A0073AAA	21.7	12.8	11.1	05P00620-0064	05P00620-0070	FU-000809	3	FU-002084
125	4A0180	4A0105AAA	27.8	17.7	13	05P00620-0075	05P00620-0146	UFU000374	3	UFU000378
150	4A0216	4A0105AAA	27.8	17.7	13	05P00620-0075	05P00620-0146	UFU000374	3	UFU000378
200	4A0260	4A0150AAA	27.8	17.7	13	URX000175	URX000176	UFU000375	3	UFU000378
250	4A0304	4A0210AAA	31.5	19.7	13.8	URX000181	URX000182	UFU000376	3	UFU000122
300	4A0370	4A0210AAA	31.5	19.7	13.8	URX000181	URX000182	UFU000376	3	UFU000122
400	4A0450	4A0300AAA	31.5	19.7	13.8	URX000088	05P00620-0094	UFU000377	3	UFU000122
500	4A0605	4A0300AAA	31.5	19.7	13.8	URX000088	05P00620-0094	UFU000377	3	UFU000122

All data above represents standard rating (100% power for 60 seconds, 25% duty cycle)

R1000 Configured



The R1000 Regenerative Configured Panel comprises of the appropriate R1000 converter and all necessary external components.

The R1000 Configured Panel is sized based on NEC horsepower so that any drive can be used in conjunction with this package. The drive and regenerative kit should be sized 1:1 based on horsepower.

R1000 Configured Panels are designed for demanding “hold-back” type applications, such as elevators and escalators. All regeneration energy is transferred to the incoming power lines.

All panels are sized for applications requiring continuous energy dissipation (100% regenerative torque for 60 seconds). The overload rating is 150% torque for 30 seconds, 200% peak torque.

R1000 Configured Panel Connection Diagram

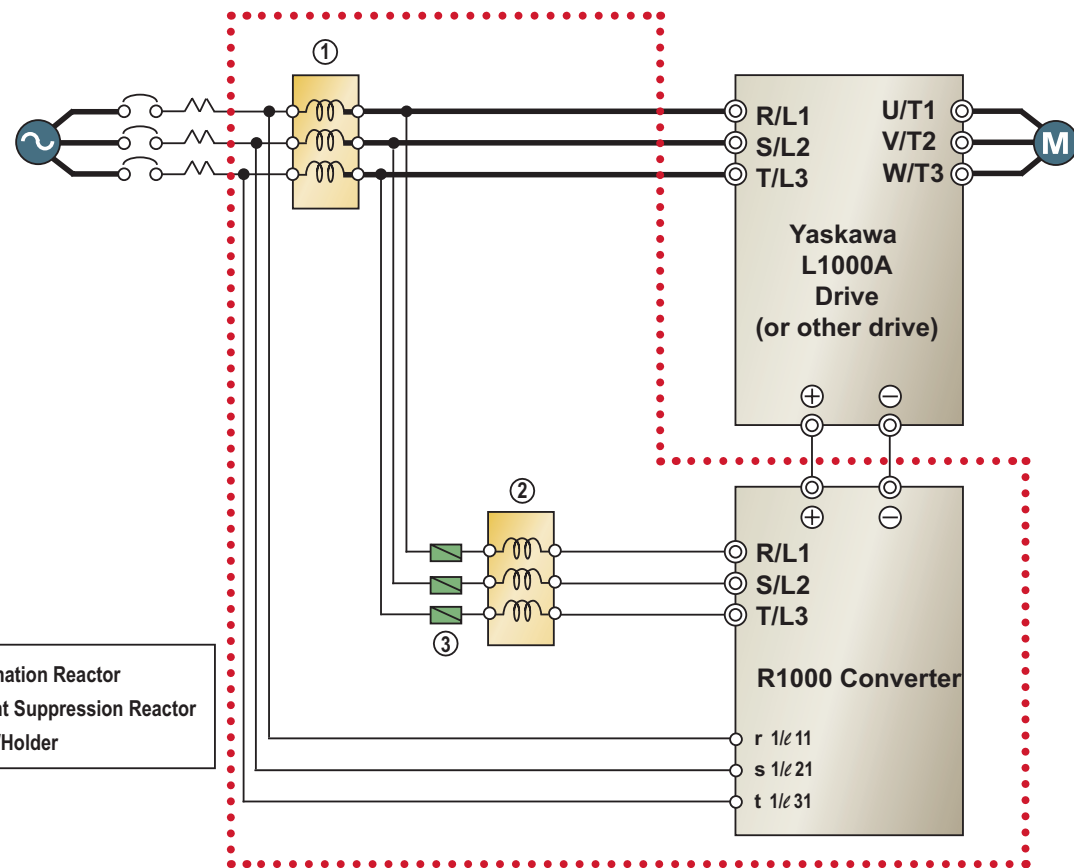

= Included with Panel

Regenerative Configured Panel Specifications and Weights

	Max Applicable Motor (HP)	L000A Model CIMR-LU□	Configured Panel Part Number R1000-□	Physical Dimensions (in)			Approximate Weight (lb)	Standard Enclosure	Heat Loss (W)
				H	W	D			Total
200V Class	15	2011	R1UC2A0010	42.43	12.15	12.73	84	UL Type 1 (W1)	373
	20	2015	R1UC2A0014	42.43	12.15	12.73	98		458
	25	2018	R1UC2A0017	42.43	12.15	12.73	107		564
	30	2022	R1UC2A0020	42.43	12.15	12.73	107		664
	40	2030	R1UC2A0028	42.43	12.15	12.73	117		818
	50	2037	R1UC2A0035	45.43	16	13.16	144	UL Type 1 (W2)	1040
400V Class	15	4011	R1UC4A0010	42.43	12.15	12.73	74	UL Type 1 (W1)	245
	20	4015	R1UC4A0014	42.43	12.15	12.73	75		302
	25	4018	R1UC4A0017	42.43	12.15	12.73	88		323
	30	4022	R1UC4A0020	42.43	12.15	12.73	109		474
	40	4030	R1UC4A0028	42.43	12.15	12.73	112		484
	50	4037	R1UC4A0035	45.43	16	13.16	156	UL Type 1 (W2)	622
	60	4045	R1UC4A0043	45.43	16	13.16	159		718



Yaskawa is the leading global manufacturer of low and medium voltage variable frequency drives, servo systems, machine controllers and industrial robots. Our standard products, as well as tailor-made solutions, are well known and have a high reputation for outstanding quality and reliability.